

TrustFall

The ButterCats:

CEO–Venkatraman Varatharajan, CIO–Emily Wang, CTO–Sumanth Sura, CMO–Shuling Lin

Massachusetts Academy of Math and Science

Advanced STEM with Scientific and Technical Writing

Instructor: Kevin Crowthers, Ph.D.

Worcester, MA. 01605

We would like to acknowledge Dr. Kevin Crowthers, Pavel Loven, and Christine Cerqueira for their assistance and guidance through the development of our device.

Introduction

As humans age, they become more prone to health complications. One of the most serious complications they can face is falling. This risk is so high that 35% of adults over the age of 65 experience a significant fall every year; for adults over the age of 70, this statistic rises to 45%. Falls are common amongst older adults because they are prone to develop factors that increase a person's chance of falling such as osteoporosis, decreased cognitive ability, and issues with balance and walking (WebMD Editorial Contributors, n.d.). As a result of their increased risk, elderly individuals may use a cane or walker to help stabilize themselves (Christine Cerqiera, professional communication, 2/3/23). However, even with numerous preventative measures, older citizens are still at risk of falling while going about their day-to-day life. These falls are a serious health concern for the elderly as one out of every five falls results in a serious injury such as broken bones or a head injury (CDC, 2021). However even with these preventative measures environments such as uneven terrain still pose a risk to elderly individuals trying to go about their day to day life. Such dangerous accidents should be avoided at all costs as for older adults, 95% of hip fractures are caused by falling (CDC, 2020).

Many devices exist to prevent a fall, but there is no readily available device to protect a user in the event of a fall; this is where our device comes in. TrustFall is a device that was created to cushion an individual in the event of a fall. If a fall were to occur, an accelerometer and machine learning algorithm will register the fall and an airbag-like device will activate before they make contact with the ground. This device was created for all elderly individuals who have a risk of falling or may become fall-risk in the future. This document is designed to provide information to fall-risk individuals, healthcare professionals, and others in order for them to be informed about our device and understand the various aspects that are incorporated in TrustFall.

Market Research

Before our device was created there were a few devices that we looked into in order to figure out what works, what does not work, and what should be improved. These devices are the WOLK Hip Airbag, Tango Belt, and Airbag Jacket (Botonis et al., 2022; Quigley & Tarbert, 2021; (South China Morning Post, 2021).

Wolk Hip Airbag

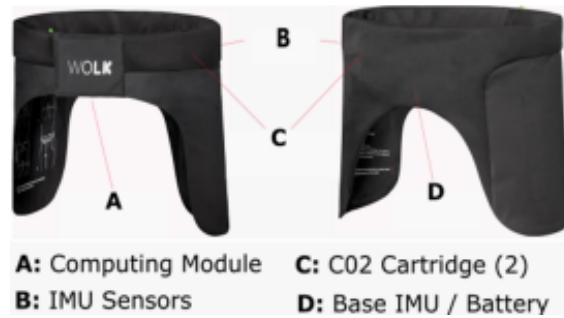

Figure 1. *The WOLK airbag*, with airbag not deployed and primary parts labeled (Botonis et al., 2022).

Pros:

- The airbag deploys quickly—activation time of 0.75
- The device deploys accurately as it contains 6 precision sensors
- The device uses CO₂—a safe and readily available resource.
- Covers a wide surface area around the hips
- System automatically contacts someone during a fall

Cons:

- Cumbersome design; does not fully look like a belt
- Expensive (\$800)

Tango Belt



Figure 2. *Tango Belt*. The tango belt, with airbags undeployed (Quigley & Tarbert, 2021).

Pros:

- Position sensors and 3D sensors on the belts, combined with smart app technology—allows monitoring of patient adherence, balance, and gait
- A wearable, belt-like device
- Specifically designed for the population most at risk of hip fracture
- Will sound alarm to alert staff nearby of the fall

Cons:

- Design, though not as bulky as hip protectors, is still bulky and does not fully look like a belt
- Does not call for emergency services in the case of the fall, and the alert system depends on people being nearby to help
- Must be removed for charging

Airbag Vest

Figure 3. Airbag jacket while deployed (South China Morning Post, 2021).

Pros:

- Activates within 0.18 of a second
- Contains a chip that processes 2,000 calculations per second and monitors posture changes
- Airbags can be worn compactly as jackets and belts
- Two designs available: one to protect the head and one to protect the hips

Cons:

- Requires a 6 hour charge for one week
- The part of the body that normally hits the ground—hips and shoulders—is not always protected
- The airbag itself does not have a lot of depth and may not sufficiently cushion the falls of clients

After we finished the Market Research we realized that for our project we wanted to prioritize client safety and access to the device. Most of the devices we looked at utilized materials that would make it hard or expensive to use the device on a day to day basis. Therefore we chose to move forward with CO₂ canisters as the source for inflation. With CO₂ the client can easily acquire the materials and the material will be safer than explosive alternatives.

Initial Designs

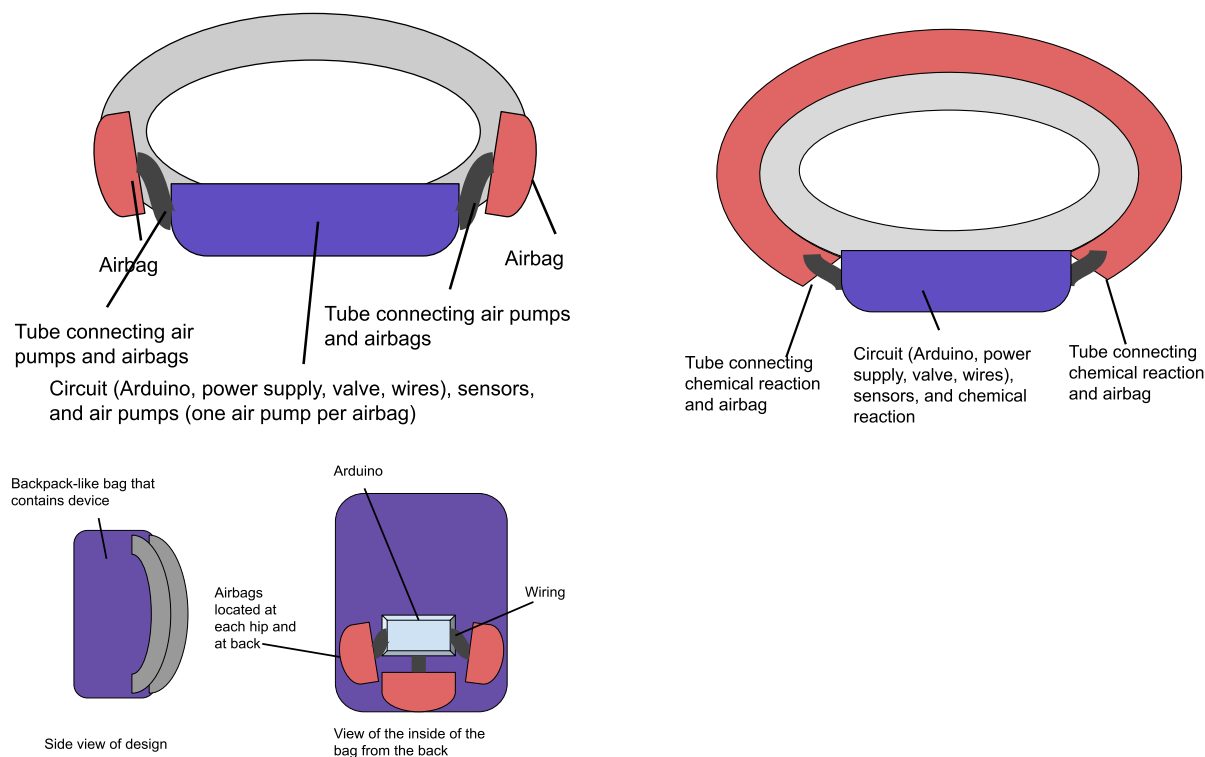

Figure 4. Previous Designs. Figure 4a, 4b, and 4c, are the preliminary designs we created for the PDR and CDR. These images are neater versions of the original sketches.

One of the first designs we drafted was a dual airbag system that utilized air pumps to fill up the airbag after the Arduino and accelerometer registered a fall. This design was created because we were worried that the activation method of our devices would be safe; at the same time, we were worried that the air pump would be too slow to inflate the airbags. The second design involves one airbag that expands around the user's entire waist while utilizing the chemical guanidine nitrate which decomposes into N_2 gas when ignited. The benefit to this design is that a large airbag would make sure that all parts of the waist would be protected but the downside is that it utilizes a lot of materials, and a dangerous inflation method. The third design was an experimental design we created to see if we could put the weight of the device in another location. This led to a backpack-like device that contains three airbags that would activate independently of one another. This design, although beneficial for planning purposes, ended up as the design we would be least likely to pursue as the algorithm would be difficult to implement before the end of STEM II. Additionally, a backpack would be the most bulky out of all of the designs which is something our product is trying to avoid.

Current Design

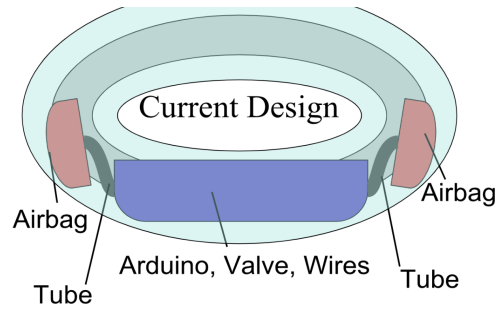

Figure 5. Current Design. This design most similarly represents Figure 4a but it changes the activation material and includes fabric over the entire device.

The design we ended up implementing, is most similar to Figure 4a as it contains two airbags, one for each hip. The activation and wiring for the device is located at the front of the client in a bag that hangs around the waist. The airbags, when activated, will be inflated with CO₂ canisters that are also located in the front of the bag while tubing brings the air to the airbags.

We decided to implement this design after we had conducted our Critical Design Review because after the Proof of Concept, we realized that two airbags would allow us to ensure that the airbag would inflate evenly. In addition,

we were able to realize that this design would fit more of our criteria (see Appendix A). This is mainly due to the use of pressurized CO₂ which would allow the device to inflate safely.

Build Process

Circuit Wiring

Materials:

- Arduino Uno
- 9V battery
- 12V battery
- Arduino battery adapter
- 4 female-to-female wires
- 8 male-to-female wires
- GY-521 MPU6050 3-Axis Gyroscope and Accelerometer IMU
- 2 ZE4F18012V water solenoid valves (Ximimark valve)

Methods:

1. Install and set up Arduino IDE
2. Go to <https://github.com/TrustFall-AT/activation-algorithm.git> and install TestCode.ino from <https://github.com/vaakash1/activation-algorithm.git>
3. Attach the materials listed above using the following instructions and schematic

How to attach components to the Arduino: (the second ID refers to the terminal on the Arduino)

- 9V Battery
 - Positive to VIN
 - Negative to GROUND
- Accelerometer
 - GND to G
 - VCC to V
 - SCL to A5
 - SDA to A4
- Power Controller
 - IN4 to I7
 - IN3 to I8

How to attach additional components connected to Power Controller: (the second terminal written is on the Power Controller)

Valve

- One terminal to OUT3
- Other terminal to OUT4
- Y junction wire - IGND on Arduino and positive end of 12V to GND on power controller

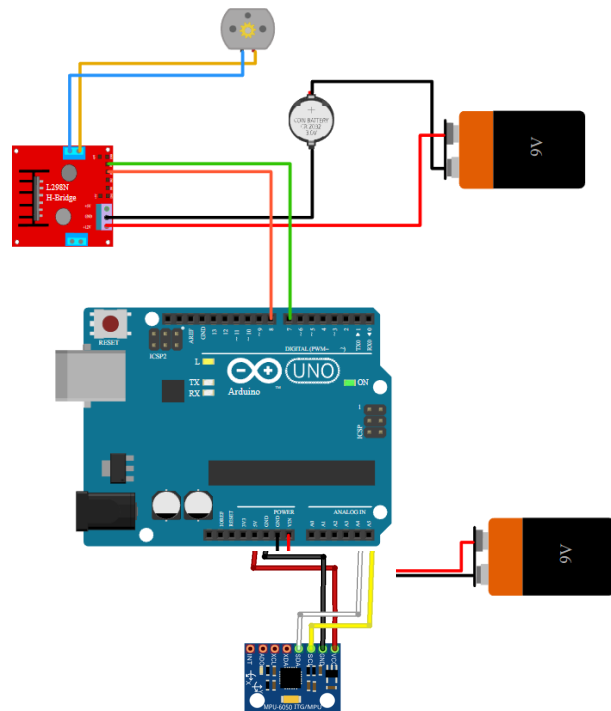

Figure 6, *Circuit diagram for the hardware*. Includes accelerometer, power controller, 9V battery, 12V battery, and Solenoid valve.

12V Battery (made from 9V and 3V)

- Positive end to +12V
- Negative end to GND

Airbag

Materials:

- 0.25 linear yard 58" 400 D. heat sealable coated packcloth
- T-Shirt Press (available at WPI campus)
- Scissors

Methods:

1. Create templates as shown in Figure &

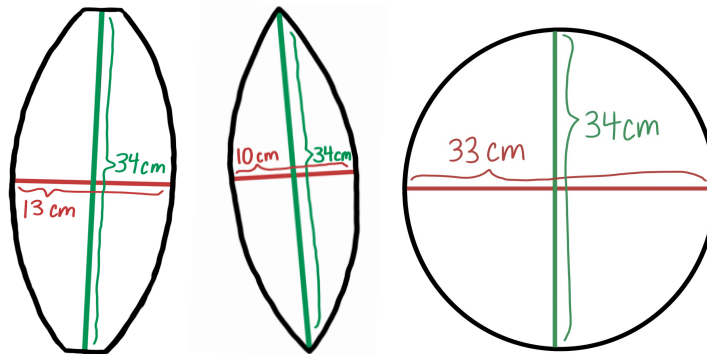

Figure 7. Airbag templates. Three templates that were cut from heat sealable fabric. From left to right: Pattern A, Pattern B, and Pattern C.

2. Cut two Pattern As , two Pattern Cs, and four Pattern Bs from the heat sealable fabric with a seam allowance of about three centimeters all around the design for heat sealing
3. Heat seal the fabric inside out, with two Patterns placed on each side of a Pattern B, oriented in the same way as shown in Figure 8

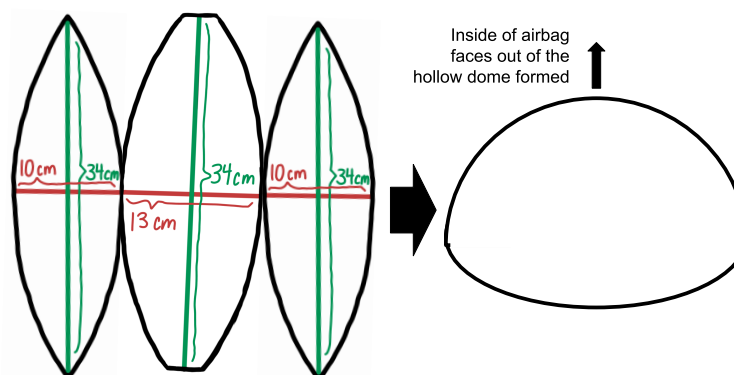

Figure 8. Step 2. Line up the long edges of the petals and the vase. Seal such that they form a dome with the inside of the airbag facing out.



Figure 9: Sealing Airbag. A T-shirt press was used to heat seal the fabric seams. Only the seam allowance is heat sealed.

4. Place the dome made in step 2 over the Pattern C and heat seal, inside out, leaving a gap.
5. Invert the airbag through the gap in the fabric that has not been sealed.
6. Repeat with remaining pieces.



Figure 10. Airbag after sealing seams. One of the airbags after sealing of seams and inversion of the fabric



Figure 11. Airbag after sealing seams and inverting. One of the airbags after sealing of seams and inversion of the fabric

Final Product

Materials:

- All previously created items
- 2 CO₂ bike pumps
- 46 inches of vinyl tubing
- Duct tape
- Fanny pack
- Fabric

Methods:

1. Cut the tubing into 2 19-inch pieces and 2 4-inch pieces
2. Attach one end of the 4” tubing to the bike pump and the other end to the inlet port of the valve by expanding the tubing with the blow dryer and pliers until it can attach onto the bike pump
3. Attach one end of the 19” tubing to the exit port of the valve and seal the other end inside the airbag
4. Attach the valves to the Power Controller as described in the hardware section.
5. Place all hardware inside the fanny pack
6. Ensure that the airbags are properly located at the user’s hips
7. Cover the airbags with fabric

Design Studies**Airbag Quality Study**

19 May 2023

Purpose

The purpose of this study was to test the robustness of our handmade airbag in order to see if it could withstand the force of an impact and if it could withstand multiple impacts. Up until this test it was unclear whether or not the airbag we created would be able to withstand the impact of a fall.

Independent Variable:

The amount of force applied to the airbag and how the force is applied to the airbag.

Dependent Variable:

How the airbag reacts in response to the force applied.

Hypothesis:

If force is applied to the airbag repeatedly while the airbag is inflated, then the airbag will be able to withstand the force and no damage will occur.

Materials:

- Airbag
- Bicycle pump
- Duct tape
- Heavy book
- Hand
- Poland Springs water bottle

Methodology:

1. Take the airbag and place it over the nozzle of the bicycle pump.
2. Take the duct tape and seal the airbag onto the bicycle pump.
3. Inflate the airbag with the pump.
4. Once inflated, press down on the airbag in order to see if there are any holes.

- a. If there is a major hole, repair it and complete Steps 1-4 again. Minor holes are fine and are even better for the device, as they become a means of deflation after deployment.
5. Re-inflate the airbag.
6. With various items, trial different ways of applying a force onto the inflated airbag.
7. Record results.

Raw Data:

Table 1. Airbag Quality. Multiple objects were dropped onto our inflated airbag and the result was recorded

Force Application	Outcome
Dropping a book from one foot above the airbag	The book bounces off the airbag.
Dropping a book from waist height 2-3 feet above the airbag	The book bounces off the airbag.
Dropping an iPhone from waist height	The phone bounces off the airbag.
Rapidly press down with a water bottle	The airbag resists the compression but does still compress down.
Rapidly press down with a hand	The airbag resists the compression but does still compress down.
Rapidly press down with a book	The airbag resists the compression but does still compress down.
Chop motion from high up	The airbag deflated slightly, but the hand did not touch the ground.
Leaving the airbag inflated overnight	In the morning the airbag was still inflated.
Person of ~125 lbs stepping on airbag with one foot	Airbag deflates slightly but still resists the pressure; foot does not touch the ground.
Person of ~125 lbs standing on airbag	Airbag deflates slightly but still resists the pressure; feet do not touch the ground.
Person of ~125 lbs jumping on airbag	Airbag deflates slightly but still resists the pressure; feet do not touch the ground.

Results and Analysis:

After all of the tests, the airbag was in a fairly good condition: it was sealed adequately tightly, and could withstand significant impact from a force of at least 125 N. The tests that involved dropping objects from various heights and a person jumping onto the airbag informed us that the airbag would most likely be able to withstand the force of an adult human falling on it. We use the word most likely here because although this test is meant to test the strength of the airbag, these tests are not perfect

representations of the force of a fall. While we did aim to emulate the force of a fall by jumping onto the airbag, we were unable to actually fall onto the airbag due to safety concerns.

Future Work:

In the future we need to look into the long term use of the airbag to see if the airbag can withstand repeated falls and daily use. We also need to test the airbag with users of different weights and jumping on it from different heights.

Valve Activation Study– Air

18 April 2023

Purpose:

This test was meant to determine if we could pass air through the valve. The valve would be used to pass CO₂ from our CO₂ canister into the airbag. Thus, it was necessary to conduct a study to determine if our valve allowed air to flow through and simultaneously prevented air from leaking out.

Independent Variables:

The independent variable was the amount of air being passed through the valve. The amount of air was increased through the trials. The air was contained in balloons. The air-containing balloon was attached to the inlet port of the one-way valve each time, then passed through the valve to an empty balloon attached to the exit port.

Dependent Variables:

The dependent variable was the final state of the balloon at the exit port. This was determined qualitatively by observing whether or not the balloon at the exit port inflated a visible amount.

Hypothesis:

If the valve is in the closed position, then the air will remain in the original balloon; if the valve is in the open position, then the air will travel through the valve and fill up the other balloon,

Materials:

- Rubber balloons
- Valve
- Voltage source
- Wires (connecting the voltage source to the valve)

Hypothesis: *The air will pass through the valve without leakage and inflate the exit port balloon until the pressures are equal in both balloons.*

Methodology:

1. A balloon was filled with air.



Figure 12. Balloon filled with air.
The balloon filled with air which will be attached to the inlet of the valve.

- The air-filled balloon was attached to the inlet port of the valve. The empty balloon was attached to the exit port of the valve.

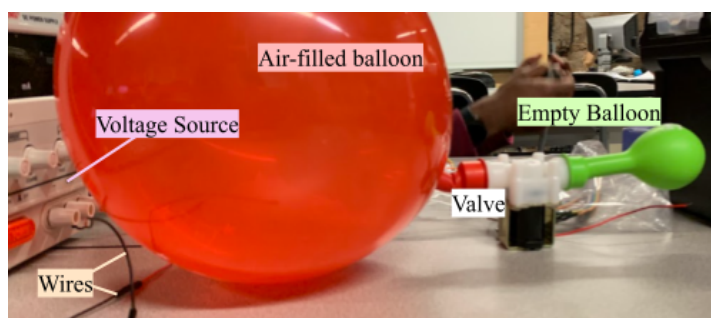

Figure 13. Balloons attached to the valve. The valve (white) with the two balloons attached. The air-filled balloon (red) is attached to the inlet port, and the empty balloon is attached to the exit port. The valve was connected to the voltage source using wires.

- The voltage source was turned on and 12 volts were run through the valve to open it. Qualitative data of whether or not the exit valve balloon inflated was taken.

Results and Analysis:

Table 2 Balloon Valve Trial Observations. A table displaying the results of our five valve tests using air. Trials are documented in chronological order

Trial Number	Did the exit valve balloon inflate? (Yes/No)	Additional Comments
1	yes	The pressure of the air is not sufficient to expand the exit valve balloon to the point of stretching the rubber.

2	yes	N/A
3	yes	N/A
4	yes	The valve allows leakage from the exit valve to the inlet valve.

The valve allows air to travel through it until pressures are even. We observed that, when we had the gas-filled balloon at the inlet port, the empty balloon at the exit port, and the valve opened, the exit port balloon inflated within two seconds, suggesting that a faster speed may be attainable using the highly pressurized gas stored in our air canisters. Some leaking of air was observed. When an air-filled balloon was placed at the exit port of the valve, and an empty balloon at the inlet port, we observed the balloon at the inlet port filling with air, even when the valve was closed. However, it did not fill up as quickly or as much as when we had the gas-filled balloon at the inlet port, the empty balloon at the exit port, and the valve opened. Such a result shows us that the valve allows for some leakage of gas, though further investigation, preferably using the CO₂ canister and airbag, is needed to determine the extent of leakage and whether or not it significantly impacts the inflation of our airbags.

Future Work/Decisions Made:

We could obtain a valve which will not allow air to leak out and test it using the same materials and methodology to ensure air is able to pass through and does not leak out. Alternatively, we could test the current valve with a CO₂ canister and an airbag. If the leakage does not cause immediate deflation of the airbag, it may be beneficial to our project, as a small amount of steady leakage would allow a deployed airbag to gradually deflate.

Valve Activation Study – Water

ADR

13 April 2023

Purpose:

This test was meant to determine if we could pass water through the valve, which was intended for use with water. The valve would be used to pass CO₂ from our CO₂ canister into the airbag. Thus, it was necessary to conduct a study, initially using water, to determine if our valve allowed fluids to flow through.

Independent Variables:

The independent variable was the amount of water being passed through the valve. The amount was increased throughout the trials. All water was contained in gloves, due to the unavailability of balloons at the time of the test. The water-containing glove was attached to the inlet port of the one-way valve each time, then passed through the valve to an empty glove attached to the exit port.

Dependent Variables:

The dependent variable was the final state of the glove at the exit port. This was determined qualitatively by observing whether or not the glove at the exit port inflated a visible amount.

Materials:

- Large nitrile exam gloves
- Valve

Hypothesis:

The water will travel from one glove through the valve into the other, with minimal leakage.

Methodology:

1. A glove was filled with water.



Figure 14. Glove filled with water. The glove filled with water which will be attached to the inlet port of the valve.

2. The water-filled glove was attached to the inlet port of the valve and secured using a hair tie. The empty glove was attached to the exit port of the valve and also secured using a hair tie.

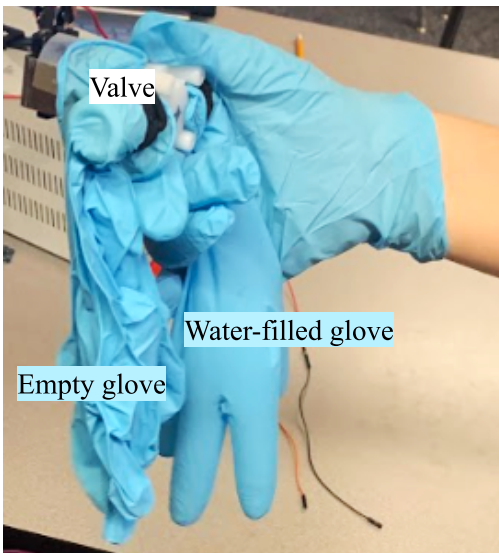

Figure 15. Gloves attached to the valve. The valve (white) with the two gloves attached. The water-filled glove is attached to the inlet port, and the empty glove is attached to the exit port. Gloves were worn as a precaution to prevent electric shock.

- The voltage source was turned on and 12 volts were run through the valve to open it. The valve was positioned such that the water-containing glove was held above the valve and the empty glove was below, allowing water to flow through the system.

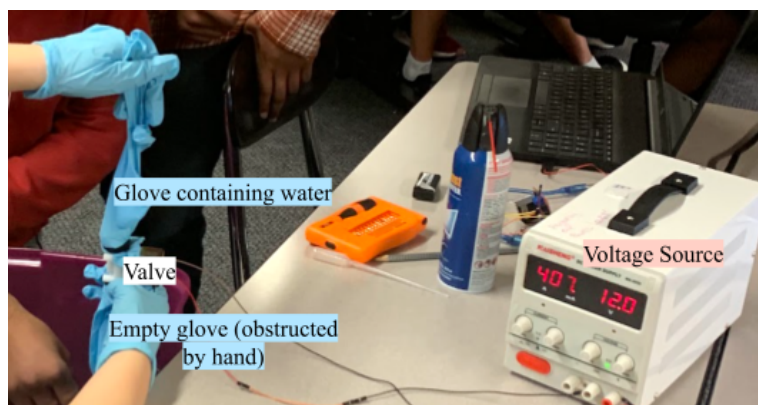

Figure 16. Valve test with water in progress. The valve (left) is opened after receiving 12 volts from the battery source (right). The glove containing water is held above the valve, allowing water to flow down and through the valve.

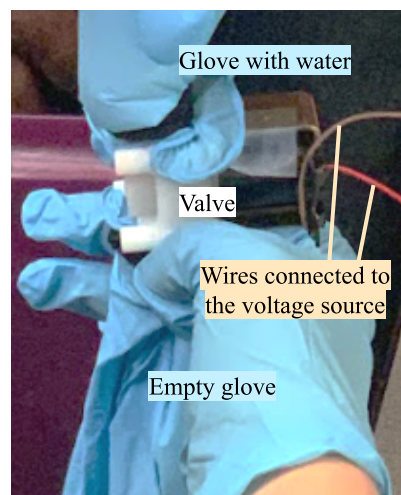

Figure 17 Close up of valve water trial. A close up of the system of the valve, water, and gloves used to determine if fluid in the form of water could pass through the valve.

Results and Analysis:

Table 3. Glove Valve Trial Observations. A table displaying the results of our five valve tests using water. Trials are documented in chronological order.

Trial Number	Did the water travel to the exit valve glove? (Yes/No)	Additional Comments
1	yes	The water trickles through the valve. It will need to be determined if gas travels through faster.
2	yes	N/A
3	yes	N/A

The valve allows water to travel through it, albeit a little slowly. No leaking was observed. Thus, in our next trial, we shall try the valve with gas to ensure that the valve does not allow for a significant gas leak. It is possible that the slow movement of the fluid may be addressed by the higher pressure of our CO₂. Thus, observing the valve's performance with a CO₂ canister may also be beneficial.

Future Work/Decisions Made:

In the future, we should test if the valve allows air to pass through without leakage, and whether the air can pass through the valve quickly, which may be determined by seeing how fast it inflates the exit port glove.

Fall Detection Algorithm Study

ADR

19 May 2023

Purpose:

The purpose of this design study was to decide which structure of fall-detection ML model was best in terms of both runtime and accuracy on an Arduino. The algorithm's ability to detect a fall before it happens and give time for the airbag to inflate was tested.

Independent Variables:

Three factors were changed across trials in this study: algorithm type, fall type, and non-fall type. To make the best choice on what fall detection algorithm to use, it is necessary to test both falling and non-falling data. In order to get an understanding of how a model may react in specific scenarios, we tested these requirements in two types of each. For non-falling trials, we tested sitting and walking, while in falling we tested pivoting and sliding falls. For both sitting and walking, the same person was chosen to complete the trial, to ensure as little random variation as possible. The person walked or sat for 20 seconds. For fall, we are unable to use humans to collect falling data, as this would raise safety concerns, so we used a PVC pipe to stand in for a human. For a pivoting fall, the PVC pipe was held in place for three seconds, to allow for the Arduino to finish setting up, and then it was let go from a vertical position. The PVC pipe was caught when sufficiently close to the ground. We induced a slipping fall by repeating the same methodology as the PVC pipe on a surface with low friction, thereby allowing the PVC pipe to achieve a more vertical and realistic fall.

Dependent Variables:

The dependent variables are the percentage with which the model was able to accurately determine whether or not a fall has occurred. For the trials which included a fall, it was also important to measure the time between activation and actual fall.

Hypothesis:

The machine learning model will be able to detect a fall more than 90% of the time and at least 0.5 seconds before the impact of a fall.

Materials:

- Arduino with code from <https://github.com/TrustFall-AT/activation-algorithm>
- An accelerometer
- A pouch
- A pipe around 6 feet tall
- Zip ties (or any material that can fasten the pouch to the pipe)
- A slippery surface

- A non-slippery surface

Methodology:

Setting up the Arduino: the Arduino was linked to an accelerometer and an SD card reader using the schematics shown below.

Testing a falling trial

1. The arduino was securely placed inside of the pouch. (NOTE: The accelerometer was placed in a separate compartment to ensure it does not move. This action helped minimize random error from the accelerometer's readings.)
2. The pouch was securely mounted to the pipe.
3. The reset button was pressed.
4. The person letting go of the Arduino waited for three seconds.
5. The person let go of the Arduino and caught it when sufficiently close to the ground.

Testing a walking/sitting trial

1. Follow the methodology for setting up an Arduino.
2. Put the Arduino and all its components into a pouch and fasten them securely to an individual.
3. Press the reset button while the individual is walking.

Results and Analysis:

We measure the performance of the fall detection algorithm by obtaining its accuracy on a set of activations around 0.5 seconds before falling.

The machine learning model was run 10 times to calculate the average loss, or root mean squared error between the expected output and actual output. The following table shows the accuracy of 10 random iterations of the fall detection algorithm.

Table 4. Activation Algorithm Accuracy A table displaying the results of the fall detection algorithm. Metrics measured are accuracy and root mean square loss.

Trial #	Accuracy	Root Mean Square Loss
1	0.9891	0.0104
2	0.9849	0.0151
3	0.9912	0.0090
4	0.9905	0.0094

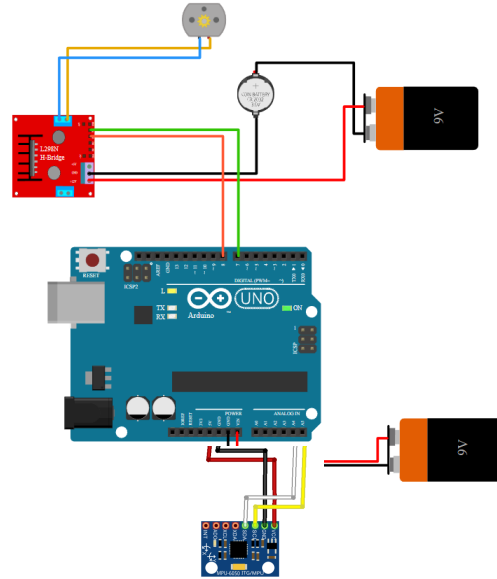

Figure 18. Circuit diagram. Contains accelerometer, power controller, 9V battery, 12V battery, and Solenoid valve.

5	0.9839	0.0112
6	0.9905	0.0092
7	0.9849	0.0139
8	0.9889	0.0096
9	0.9849	0.0152
10	0.9849	0.0151

The average accuracy and loss of the model were 0.9874 (which is 98.74%) and 0.0118, respectively. These metrics demonstrate that the model is accurate. Additionally, in order to evaluate the speed of our machine learning model, we ran some test matrices through in place of actual data and found that it was able to run in under 200 milliseconds.

Future Work/Decisions Made

In the future, we could possibly consider collecting data from different angles, so that the model is even more accurate for real-life situations. We could also test falls from different heights to adjust for clients who have different hip heights.

Final Device Summary

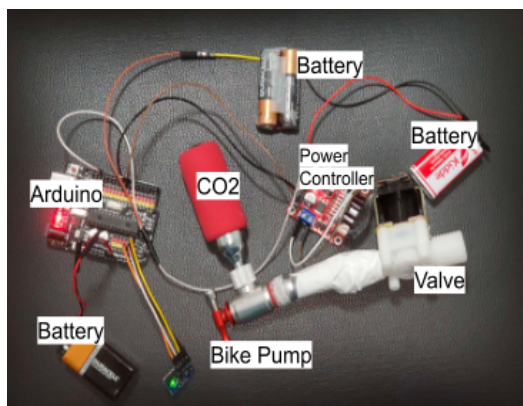

Figure 19. Arduino wiring. Our device requires: Arduino, batteries, valve, accelerometer, CO₂, bike pump, Power Controller

The three main parts of our device, algorithm, hardware, and airbag were each successful on their own. The algorithm was successfully able to detect a fall as a result of data collected by the accelerometer. Once properly wired together, the Power Controller was able to send a signal to open the valve. Finally, the airbag that we designed adequately protects a potential user and is able to withstand the force of an average teenager.

However, even with these successes we were ultimately unable to combine all aspects into a working device for our client. After the Valve Activation Study for Air, we wanted to look into other valves to use in place of the valve we used for the study because we had wanted to avoid any leakage that may occur. But due to time

constraints and limited access to materials, we ultimately had to move forward with the original valve or else we would not have had a final device at all. Towards the end of the build process, we tested how the valve and tubing would react under the high pressure of the CO₂. When the valve was in the open position, the CO₂ was able to flow freely through and inflate the airbag. However, when the bag was in the closed position, the tubing and valve were not able to withstand the pressure of an open CO₂ canister and they detached from each other. This caused an issue for us as our original activation method involved having the CO₂ canister open at all times and then opening and closing the valve. At this point we realized our plan would not work and we realized that we would not have enough time to work with a different valve or to create a different mechanism for allowing the CO₂ to enter the airbag. Since we were unable to fully implement our design, we failed to pass Requirement 2 and Requirement 6 (see Appendix B). It is also worth noting that after we had used pressurized CO₂ with the valve, we realized that we had no way to close the valve to prevent CO₂ from flowing in after the airbag had filled.

On the other hand, our group was able to meet all other requirements that we had set for this device. All materials we used were bought online and no singular item was worth over \$30. Even the materials that were on the expensive side only needed to be purchased once while the materials that needed to be replaced over use, such as batteries or CO₂ would be cheaper. The entire device was able to be placed into a pouch and be worn comfortably. Overall, the technology used in the device demonstrates that the design is scientifically valid and could produce the desired outcome; however, the design is not fully functional due to the time and materials limitations that occurred during this project.

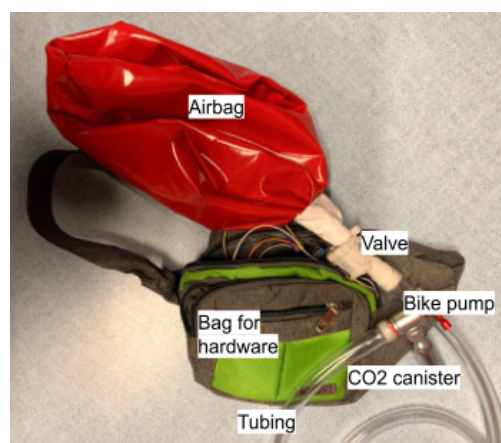

Figure 20. Final Prototype. A view of the final product with the circuitry inside the fanny pack and what the airbag connection looks like.

Future Work

As the buildup of pressure from the CO₂ canisters results in the valve and tubing separating, our next step is to explore alternatives to our current system of using valves and tubing to transfer CO₂ to our air bags. For example, we may explore different methods of sealing the connections with the tubing, using stronger materials such as epoxy (\$7.76/ 25 mL). Alternatively, we may use a different CO₂ release method. Currently, we rely on the opening and closing of our valve to regulate the flow of the CO₂ while the CO₂ canister remains open the entire time. This causes a problem when the CO₂ builds up between the tubing and the valve. Should we instead regulate the flow of CO₂ by turning the handle of the bike pump, this would allow us to stop the flow of CO₂ without having pressure build up inside the tubing, as the CO₂ would remain in the canister. More research and engineering would be required for this approach, though we believe it is a promising solution.

We also hope to refine the design of our airbag. While our current design is sturdy and functional, we feel that it may be expanded to protect a greater surface area. To explore different airbag designs, we will need more of the 400 D. heat sealable coated packcloth (\$26.50/linear yard) used in our current design. Additionally, we could investigate different methods of concealment of the airbags. In our current design, we opted for a simple draped fabric with a built-in pocket. However, we feel that it may be possible to create a more compressed design. For example, the airbag may be stored folded until deployment, and an inbuilt support may allow the fabric to have more structure and thus make the device more appealing to the eye.

Finally, if possible, it would be beneficial to replace the tubing we are currently using with one that is resistant to temperatures up to 400° C, as that is the temperature used to seal our airbags. During the sealing process, we observed that the heat was melting and thus weakening and creating fissures in the tubing. One such tubing that may fit our criteria is high-temperature rubber tubing for chemicals (\$434.50/ 10ft). As this rubber tubing is expensive, further research into different types of high-temperature tubing would be beneficial. Alternatively, options such as metal tubing and tubing built into valves may be investigated. Another possible solution is making our own tubing out of the same heat sealable coated packcloth so the tubing could easily attach to the airbag.

Any future work we would pursue would be done with communication with our client as well. We would also most likely try to find additional clients so that we could receive more feedback and information.

References

- Botonis, O. K., Harari, Y., Embry, K. R., Mummidisetty, C. K., Riopelle, D., Giffhorn, M., Albert, M. V., Heike, V., & Jayaraman, A. (2022). Wearable airbag technology and machine learned models to mitigate falls after stroke. *Journal of NeuroEngineering and Rehabilitation*, *19*(1), 60.
<https://doi.org/10.1186/s12984-022-01040-4>
- CDC. (2020, September 30). *Hip Fractures Among Older Adults | Fall Prevention | Injury Center | CDC*.
<https://www.cdc.gov/falls/hip-fractures.html>
- CDC. (2021, December 1). *Facts About Falls | Fall Prevention | Injury Center | CDC*.
<https://www.cdc.gov/falls/facts.html>
- Quigley, P., & Tarbert, R. (2021). Tango Belt: A New Smart Hip Protector Solution. *OJIN: The Online Journal of Issues in Nursing*, *26*(3). <https://doi.org/10.3912/OJIN.Vol26No03Man05>
- South China Morning Post (Director). (2021, April 19). *Chinese company designs 'airbag jackets' to protect the elderly from falls*. <https://www.youtube.com/watch?v=p9W6wNfzsIE>
- WebMD Editorial Contributors. (n.d.). *Why Do Older Adults Have More Falls?* WebMD. Retrieved March 2, 2023, from <https://www.webmd.com/healthy-aging/why-do-older-adults-have-more-falls>

Appendix A

CDR Requirements Matrix

Table 5. CDR Requirements Matrix. This table contains our four designs and whether or not they pass various requirements we set for this project.

#	Requirement Type	Requirement Statement	Level	Current Design	Dual Airbag Belt	Mono Airbag Belt with Expansion Control	Airbag Backpack
1	Functional	The device detects a fall with an accuracy of at least 90%.	1	TBD	TBD	TBD	TBD
2	Functional	The device reduces the impact of a fall by at least 60%.	1	TBD	TBD	TBD	TBD
3	Functional	The device detects a fall prior to the client's impact with the ground.	1	Yes	Yes	Yes	Yes
4	Functional	The device detects a fall at least half a second before the fall.	1	Yes	Yes	Yes	Yes
5	Functional	The device inflates to its full size in under one second.	1	TBD	No	Maybe	Maybe
6	Functional	The device deploys without causing physical injury.	1	Yes	Yes	No	No
7	Physical	The chemical(s)/gas used to deploy the airbag is not dangerous to the user.	1	Yes	Yes	No	No
8	User	The device is easy for the user to lift.	1	Yes	Yes	Yes	No
9	User	The device is easy for the user to put on.	1	Yes	Yes	TBD	No
10	User	The user can move unhindered when wearing the device.	1	TBD	TBD	No	No
11	Physical	The device is comfortable for the user to wear.	2	Yes	Yes	Yes	No
12	Physical	The device weighs less than one kilogram.	2	TBD	TBD	TBD	No
13	Physical	The airbag is able to withstand repeated falls.	2	TBD	TBD	TBD	TBD
14	Cost	The device costs under \$100.	2	Yes	Yes	Yes	Yes
15	Physical	The device is made of materials that are easily obtainable.	3	Yes	Yes	Yes	Yes

16	Physical	The chemical(s)/compressed air used to deploy the airbag shall be easily obtainable.	3	Yes	Yes	Yes	Yes
16	Algorithmic	The fall-detection algorithm uses less than 100MB of data	3	Yes	Yes	Yes	Yes

Appendix B

Final Requirements Matrix

Table 6. Final Requirements Matrix. A table displaying that reviews our final prototype and sees whether or not it passes the requirements we set.

				Our Design
#	Requirement Type	Requirement Statement	Level	Final Prototype
1	Functional	The device shall detect a fall with an accuracy of at least 90%.	1	Pass
2	Functional	The device shall reduce the impact of a fall by at least 60%.	1	Fail
3	Functional	The device shall detect a fall prior to the client's impact with the ground.	1	Pass
4	Functional	The device shall detect a fall at least half a second before the fall.	1	Pass
5	Functional	The device shall inflate to its full size in under one second.	1	Pass
6	Functional	The device shall deploy without causing physical injury.	1	Fail
7	Physical	The compressed air used to deploy the airbag shall pose no danger to the user.	1	Pass
8	User	The device shall be easy for the user to lift.	1	Pass
9	User	The device shall be easy for the user to put on.	1	Pass
10	User	The user shall be able to move unhindered when wearing the device.	1	Pass
11	Physical	The device shall be comfortable for the user to wear.	2	Pass
12	Physical	The device shall weigh less than one kilogram.	2	Pass
13	Physical	The device shall be able to withstand repeated falls.	2	Pass
14	Cost	The device shall cost under \$100.	2	Pass
15	Physical	The device shall be made of materials that are easily obtainable.	3	Pass
16	Physical	The compressed air used to deploy the airbag shall be easily obtainable.	3	Pass
16	Algorithmic	The fall-detection algorithm shall use less than 100MB of data	3	Pass

Appendix C
Bill of Materials

Table 7. Bill of Materials. Contains the price and the amount needed of each material we needed to acquire for this project.

Material	Cost	Amount Needed
USB 2.0 Cable Type A to B Male for Arduino Uno	\$3.00	1
ZE4F18012V water solenoid valves (Ximimark valve)	\$10.99 / 2 valves	2
Arduino Uno R3 Plus	\$24.00	1
GY-521 MPU6050 3-axis gyroscope and accelerometer IMU	\$6.49	1
Threaded 16g CO2 cartridges	\$16.99 / 10 cartridges	2
400 D. heat sealable coated packcloth	\$26.50 / linear yard	0.25 linear yards
Male to female wires	\$1.99 / 40 pcs	8
Clear vinyl tubing	\$9.58 / 10'	46"
Fanny pack	\$6.99	1
CO2 bike tire inflators	\$14.25	2
Fabric	\$3-4 / linear yard	2 linear yards