

Search and Rescue Robot

3rd Place Provost's MQP Competition

Introduction

This Major Qualifying Project designed and built a robot prototype of a first response unit for fire emergencies. The robot followed the guidelines and rules of the Trinity College Home Robot Fire Fighting Contest.

The robot measured temperatures, distances, and accelerations to find candles and a baby doll that emits a simulated body heat. These operations are performed autonomously.

Trinity College Fire Fighting Home Robot Competition

Entering the robot in a competition provided guidelines for the team and design constraints.

Trinity College holds an annual competition pitting robots against each other. Each robot must find two candles, extinguish them, and leave an audible beeper next to a doll that simulates the presence of a baby. Additionally, each robot must be fully autonomous. The arena is a random maze, representing a two-story house.

Our Approach

Our focus was to integrate the mechanical engineering, electrical engineering, and computer science tasks that go into designing and building a robot.

It uses multiple processors — one gathers data from the sensors and the other provides control to the whole system.

The project was made by Kevin Bobrowski (kevinmbo@wpi.edu), Francisco De Molina Cobo (frandmc@wpi.edu), and Chris Korzeniowski (cdkorzen@wpi.edu). They were 3 senior-level ECE students. The project was advised by Professor R. James Duckworth (rjduck@wpi.edu), a Professor of ECE.

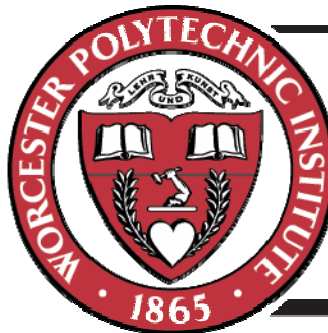
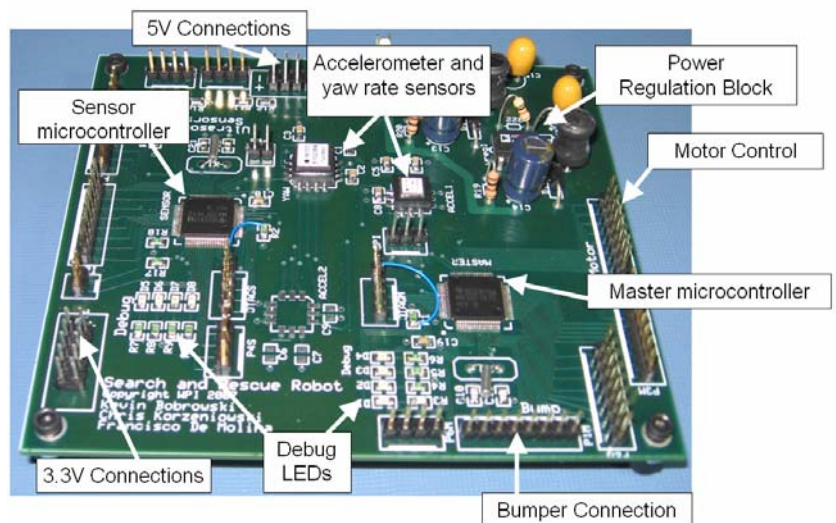
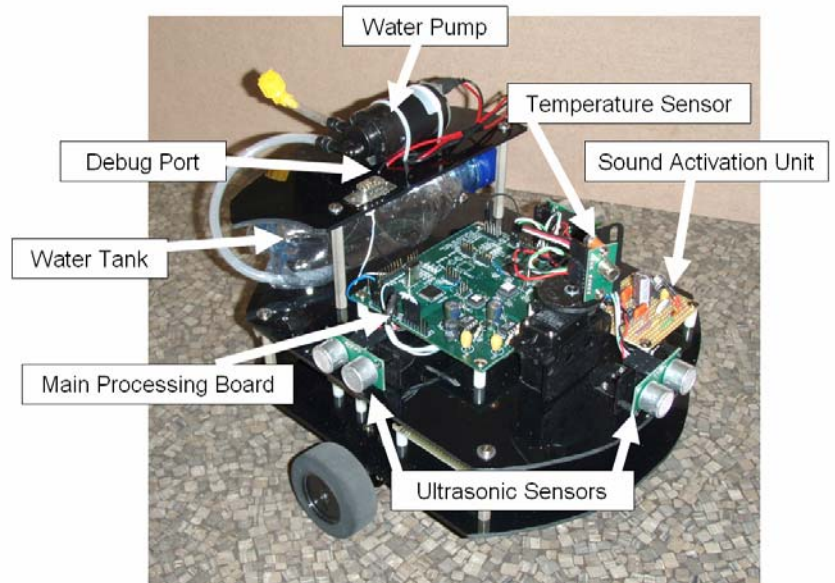

WPI