

Problem Statement

Patients suffering from neuro-degenerative diseases often suffer from finger tremors that reduce grip-ability and comfort (Adabi & Ondo, 2024; Ghosh et al., 2022).

Engineering Goal

The engineering objective of this project is to develop an affordable, accessible device that suppresses finger tremors using mechanical methods.

Background

Tremor:

- Involuntary, oscillatory muscle contractions
- Tremors affect over 4-50 million individuals globally (Song et al., 2022; Adabi & Ondo, 2024)

Hand and Finger Tremors:

- These tremors restrict day-to-day activities, cause spills, and reduce independence (Ghosh et al., 2022)
- Existing solutions include wearable gloves which reposition hand movement, neuroprosthetics, and medicine (GyroGear, 2024; Cala Health, 2023)
- These technologies do not directly target finger tremors

Design Methodology

Guiding Idea:

The guiding idea of the design was a device that could apply resistance to tremors with little force. A simple mechanical device was idealized for its low-cost and accessibility

Key (Level-1) Requirements:

- The device must suppress tremors
- The device must detect tremor behavior
- The device must be hand-worn and fit on the fingers
- The device must cost no more than ~\$125

Engineering Steps Overview:

3D arduino mount and servo mount, super-glue arduino to mount and servo to mount, attach spring to string mounted on servo, mount string to gear on servo, and then attach string to wearable finger enclosure. After, mount the accelerometer in the accelerometer mount on the wearable finger enclosure.

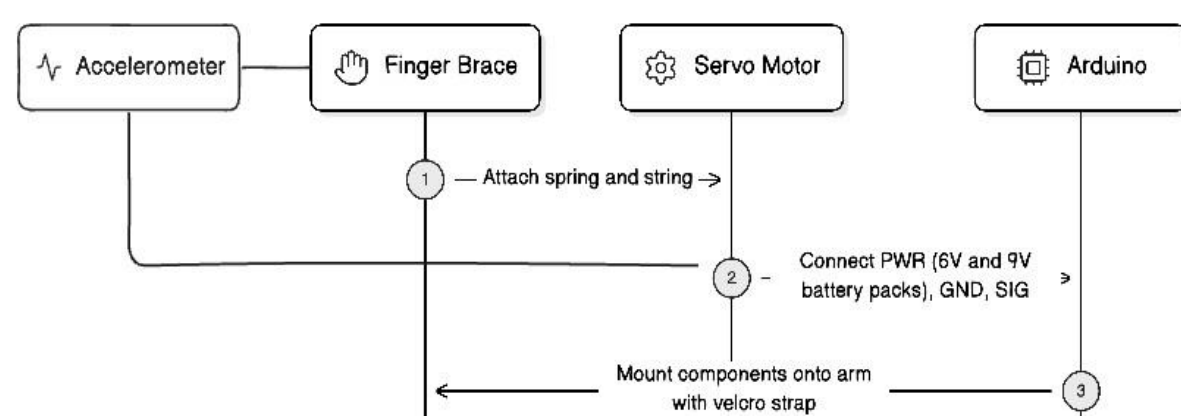

Engineering Matrix:

Criteria:	Design 1			Design 2			Design 3			Design 4		
	Raw	Weight	Total	Raw	Weight	Total	Raw	Weight	Total	Raw	Weight	Total
Suppresses Tremors:	5	5	25	10	5	50	9	5	45	8	5	40
Detects Tremors:	1	4	4	8	4	32	8	4	32	8	4	32
Wears comfortably:	3	4	12	3	4	12	1	4	4	5	4	20
Low cost to manufacture:	9	3	27	8	3	24	7	3	21	1	3	3
Maintains limb flexibility:	7	4	28	2	4	8	1	4	4	7	4	28
Total Score:			96			126			106			123

4 Main Designs/Iterations:

- The First Design** was purely mechanical, utilizing a spring pulling on a ring to constantly apply a dampening force to all tremor movement
- The Second Design Iteration 1** used an accelerometer to detect tremor oscillation, which triggers a 360° servo motor to wind a cord tied to the finger back
- The Second Design Iteration 2** The cord was replaced with a spring to employ the dampening effect used in the first design. The tremor detection is now set to initiate the device after a set period to prevent type 1 errors (false alarm)
- The Third Design** employs cords instead of a spring to pull the finger, with another cord below the hand to stabilize finger movement
- The Fourth Design (Idea in development)** replaces the motorized design with a wearable glove that employs MR fluid to reduce finger movement upon tremors, as detected with a flex sensor on each finger bend.

Final Design

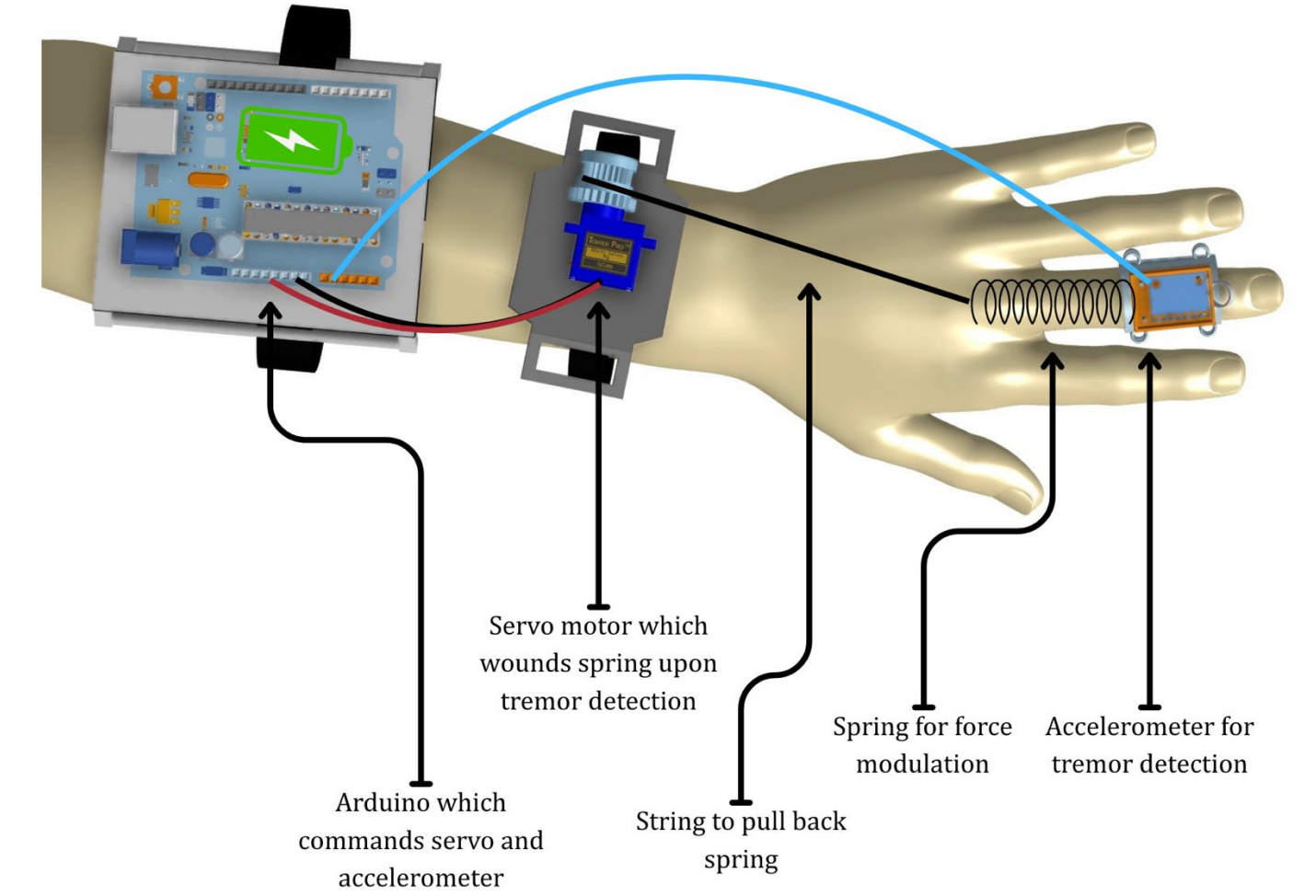

Figure 5. Final design, selected as the iterated design 2 (Figure 2) from its evaluation with the engineering matrix. The design is worn on the hand and upper arm, with a servo mount, an Arduino mount, and a mount for the actuation and accelerometer. The spring is over the hand and applies tension from the servo (Golji et al., 2026).

Design Study

Mean Tremor Reduction

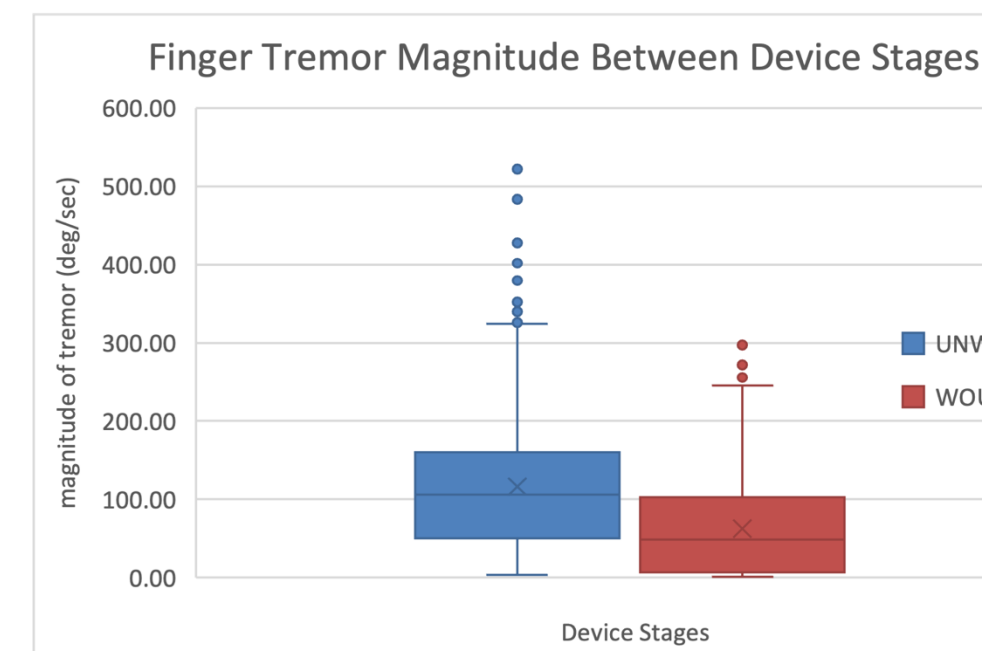

Figure 6. Box plot comparing tremor magnitude: wound stage shows significant reduction in finger tremor magnitude over unwound, highlighting effectiveness in finger tremor stabilization (Golji et al., 2026).

Mode	Mean	SD
Wound	116.2	82.8
Unwound	62.6	58.7

Statistical Analysis:
Welches T-test: to compare average tremor magnitudes per treatment stage (device unwound vs. wound)

- Accelerometer tracked instantaneous rotational speed across treatment engagement: n=1464 measurements across 5 wound/unwound cycles
- Differences in averages found to be **statistically significant** (p~0)
- Lower 2 quartiles of unwound treatment overlap significantly with upper two quartiles of wound treatment (Figure 6)
- Tremor Reduction (the difference in peak tremor to average wound): **84%**

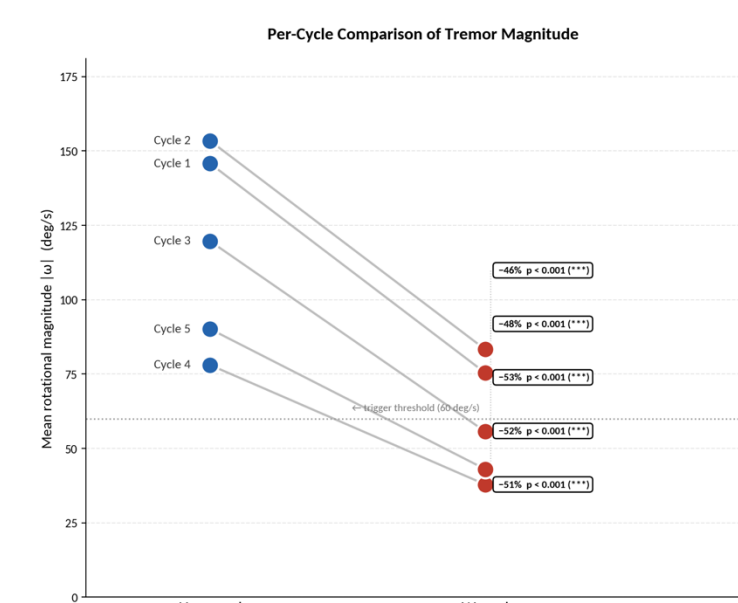

Figure 7. Graph of cycle-wise reduction in finger tremors with statistical significance (Golji et al., 2026).

Cycle-Wise Reduction

- Changes in tremor magnitude per wound-unwound cycle remained similar (Figure 7)
- Overall min and max displays strong variability (Figure 7)
- May reflect potential biases as a result of the experimental setup

Qualitative Feedback

- Students volunteered to evaluate device function
- Instructed to wear the device and oscillate their finger to simulate tremor behavior
- Post-experimental evaluation of simulated tremor suppression "on a scale of 1-10" (Figure 8)

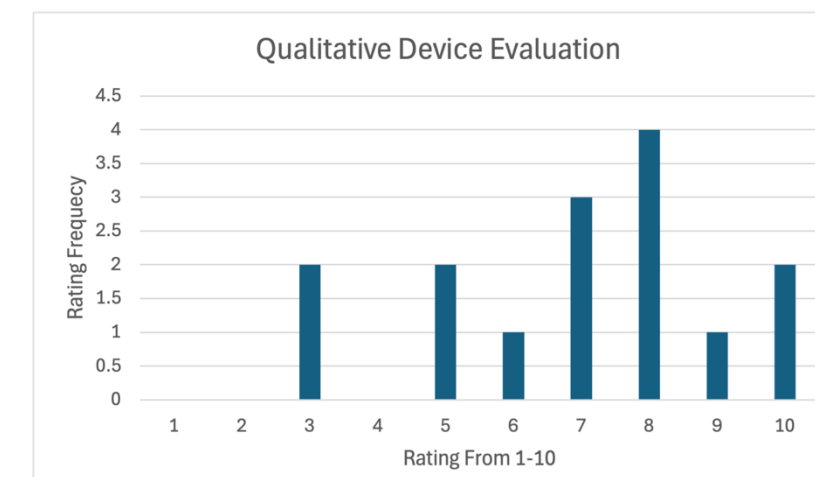

Figure 8. Bar graph comparing post-experimental qualitative observations from survey, with more than 66% rating the device a 7 or higher in terms of finger tremor reduction (Golji et al., 2026).

Design 1



Figure 1. Spring-system is attached between the finger and wrist to automatically reduce tremor-like oscillations (Golji et al., 2026).

Design 2

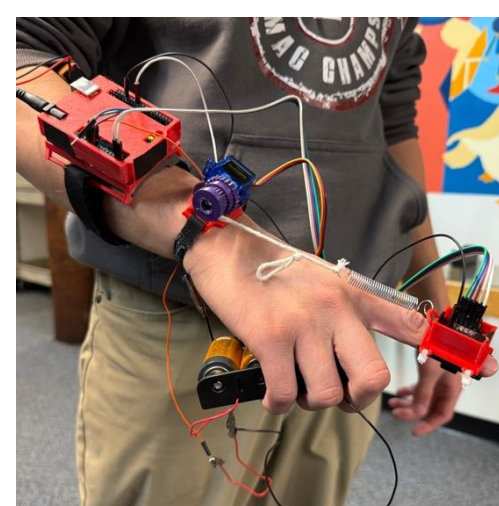

Figure 2. Servo (blue) winds back string attached to spring which pulls the finger-mount upon tremor activity (Golji et al., 2026).

Design 3



Figure 3. Two cords (blue line) pull back the top and back of finger detected during tremor activity. Springs are not used to force modulation (Golji et al., 2026).

Design 4

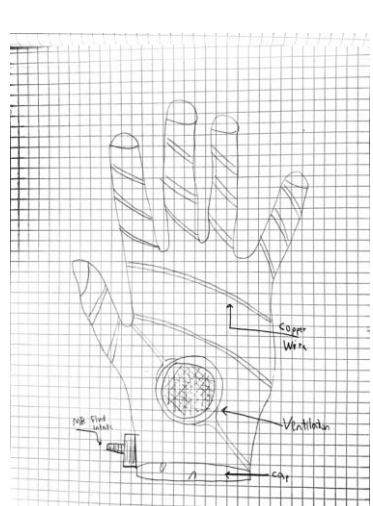

Figure 4. Design 4: copper wires (MR signalling) wrap around flexible glove. MR fluid is taken in and replaced through valve (left). System is fully sealed with small ventilation valve for comfort (Golji et al., 2026).

Testing Strategy

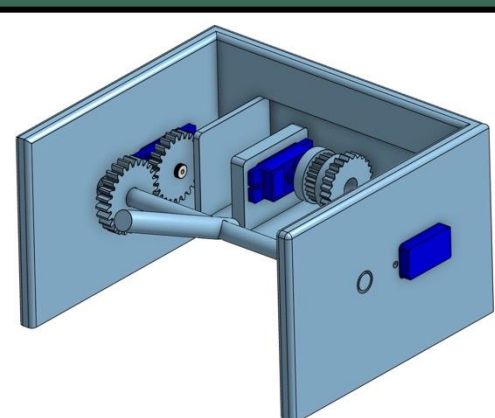

Figure 4. Testing mechanism features an oscillating rod to simulate constant tremor behavior (Golji et al., 2026).

- A testing mechanism made to simulate oscillatory rod-motion (Figure 4)
- The testing mechanism exhibited poor structural integrity, no flexibility
- Primary testing was performed on volunteers and the inventors
- To measure oscillation and tremor behavior, the tester **manually oscillated** their index finger with the instruction and effort to maintain the **same** force and energy as the device began to engage
- Accelerometer was used to track movement of the finger
- Measured for 5 cycles of device engagement

Conclusion and Future Work

- The primary design was shown to ultimately **reduce** tremor movement by a large margin
- Primary design drawbacks included it being bulky, difficult to assemble, and restrictive of active finger use
- The design was evaluated by several human participants to have a tangible impact on their simulated tremors
- Future work on the current design includes developing a spring to go beneath the hand and integrating multiple fingers into the system
- Future design plans include shifting focus towards utilizing MR fluid as opposed to the purely mechanical option

APA Citations:

Adabi, K., & Ondo, W. G. (2024). Shaking up essential tremor: Peripheral devices and mechanical strategies to reduce tremor. *Tremor and Other Hyperkinetic Movements*, 14(1), 55. <https://doi.org/10.5334/tohm.930>
Cala Health. (2023). *Cala kIQ system*. Retrieved May 4, 2026, from <https://calahhealth.com/>
Ghosh, R., Roy, D., Dubey, S., Das, S., & Benito-León, J. (2022). Movement disorders in multiple sclerosis: An update. *Tremor and Other Hyperkinetic Movements*, 12(1), 14. <https://doi.org/10.5334/tohm.671>
GYENNO Technologies. (n.d.). *GYENNO spoon*. Retrieved May 4, 2026, from <https://www.gyenno.com/spoon-en>
GyroGear. (2024). *GyroGlove: The world's most advanced hand stabilizer*. Retrieved May 4, 2026, from <https://gyrogear.net/>
Song, M., Zhang, M., & Yang, Q. (2021). The global prevalence of essential tremor, with emphasis on age and sex: A meta-analysis. *Journal of Global Health*, 11, Article 04028. <https://doi.org/10.7189/jogh.11.04028>