

ECE3204 Lecture 23

Wien Bridge Oscillator  
with AGC

Op-Amp Dominant Pole  
Compensation

Review Stability Analysis

Instability from feedback: Differentiator

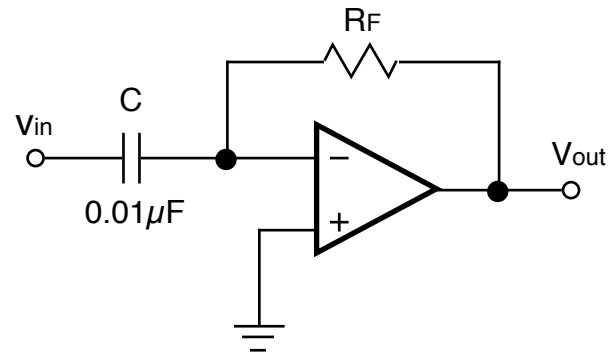

# Phase Margin Examples

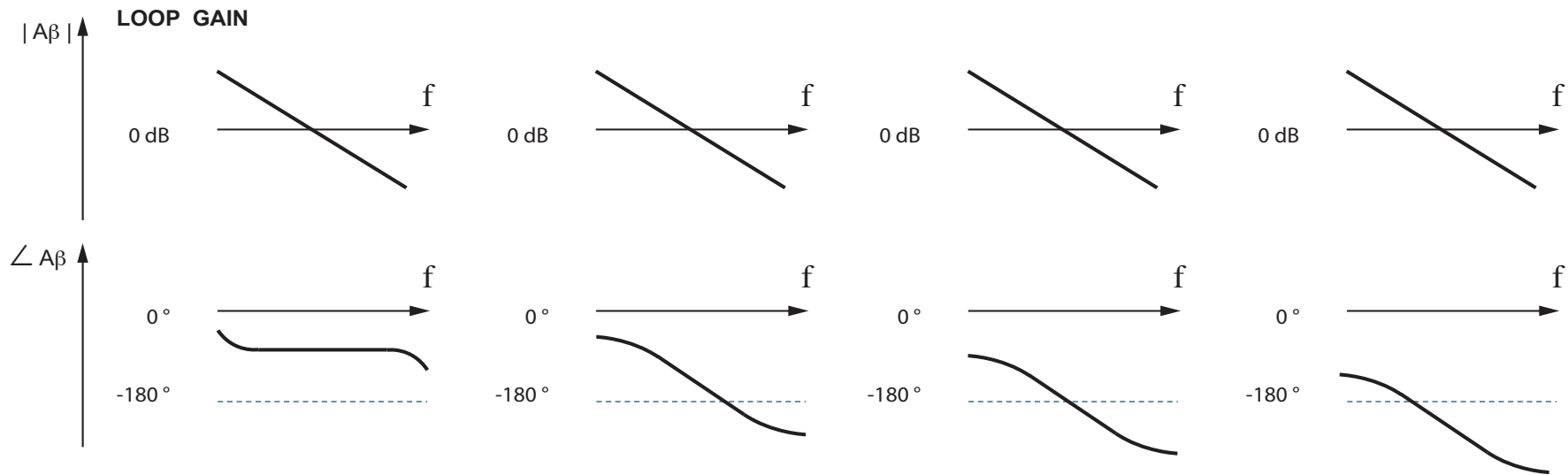

**CLOSED LOOP  
TRANSFER  
FUNCTION**

s- PLANE

STEP  
RESPONSE

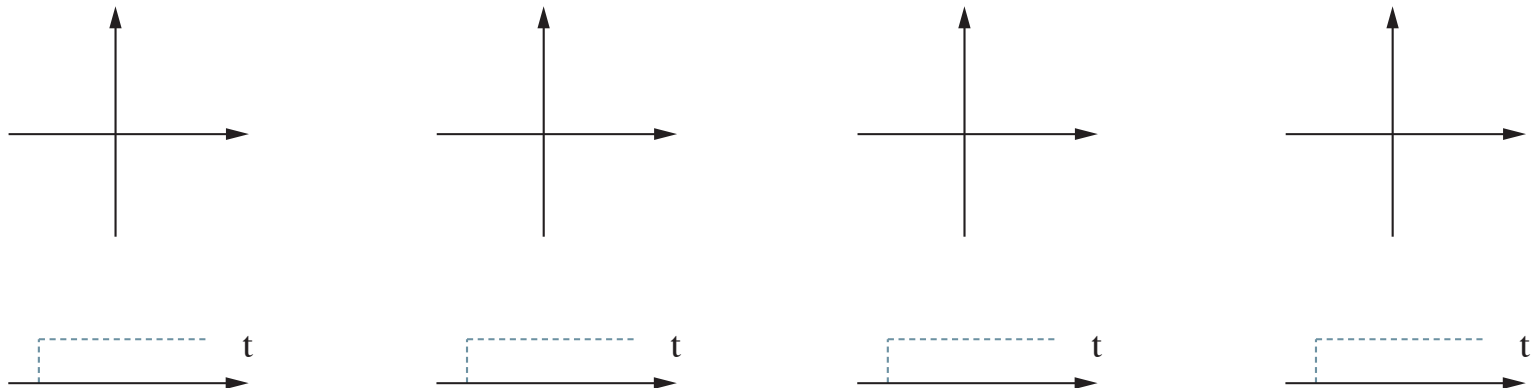

Why does op-amp Open Loop Gain look like this?

Open Loop Frequency Response

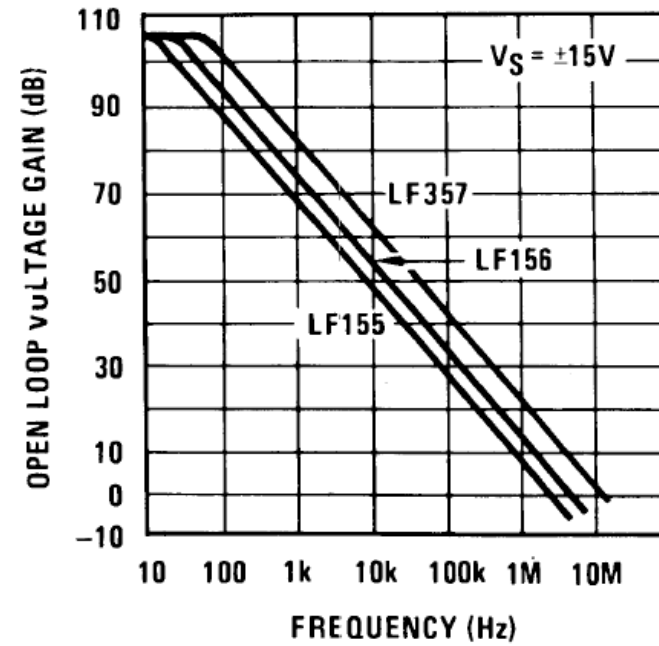

# Dominant Pole Op-Amp Compensation