

Representations of Directed Strongly Regular Graphs

Chris D. Godsil
Combinatorics and Optimization
University of Waterloo
Waterloo, Ontario
Canada, N2L 3G1

Sylvia A. Hobart
Department of Mathematics
University of Wyoming
Laramie, WY 82071

William J. Martin
Department of Mathematical Sciences
Worcester Polytechnic Institute
Worcester, Massachusetts 01609

Draft August 11, 2005

Acknowledgment: The second and third authors would like to thank the department of Combinatorics and Optimization at the University of Waterloo for their hospitality during the initial research for this paper.

Abstract

We develop a theory of representations in \mathbb{R}^m for directed strongly regular graphs, which gives a new proof of a nonexistence condition of Jørgensen [8]. We also describe some new constructions.

1 Introduction

Directed strongly regular graphs are directed versions of strongly regular graphs, and were originally defined by Duval [2]. Many results for strongly regular graphs have analogues for the directed version; in particular the eigenvalues are strikingly similar. The interplay between the straightforward eigenvalue results and the difficulties imposed by the nonsymmetric adjacency matrix makes this an interesting subject.

Interest in these graphs was recently revived by Klin, Munemasa, Muzychuk, and Zieschang [9], and there have been a number of recent papers ([3], [4], [6], [7], [8]).

In particular, Jørgensen [8] independently proved Theorem 4.2 and the characterizations of Section 5. We discovered the overlap between our work and his at the Com²Mac Conference on Association Schemes, Codes and Designs in Pohang, Korea in July, 2000. We had both proved inequalities and characterized graphs which have an eigenvalue of multiplicity 2, using different methods. The inequality given here is due to Jørgensen, but proved using representations in \mathbb{R}^m .

Section 2 of the paper gives definitions and basic results on directed strongly regular graphs. Section 3 introduces representations; Sections 4 and 5 use them to prove the inequality, and then to characterize graphs with an eigenvalue of multiplicity 2. Section 6 gives some new constructions.

2 Definitions

Suppose that Γ is a directed graph on v vertices with adjacency matrix A . We say that Γ is a *directed strongly regular graph* with parameters v, k, t, λ, μ if $0 < t < k$, and A satisfies the following matrix equations:

$$JA = AJ = kA \tag{2.1}$$

$$A^2 = tI + \lambda A + \mu(J - I - A) \tag{2.2}$$

where J is the all 1's matrix.

If A satisfies the matrix equations and $k = t$, then Γ is an undirected graph which is clearly strongly regular. If $t = 0$, then Γ is a doubly regular tournament. These have both been extensively studied, and so we exclude these two cases.

We will write $x \rightarrow y$ if there is an edge from x to y in Γ , and $x \not\rightarrow y$ if there is no such edge. We will also write $x \sim y$ if there are edges both from x to y and from y to x ; that is, $x \sim y$ if both $x \rightarrow y$ and $y \rightarrow x$. In this case, we will count these as one undirected edge, and say that x is adjacent to y .

We have given a matrix definition for directed strongly regular graphs because our methods focus on the matrix A . There is however an equivalent combinatorial definition. We say Γ is a directed strongly regular graph with parameters (v, k, t, λ, μ) if and only if

- (a) Every vertex x has in-degree and out-degree k , and is adjacent to t vertices.
- (b) Let x and y be distinct vertices. The number of vertices z such that $x \rightarrow z \rightarrow y$ is λ if $x \rightarrow y$, and μ if $x \not\rightarrow y$.

Throughout the rest of the paper, we will assume that Γ is a directed strongly regular graph with parameters (v, k, t, λ, μ) and adjacency matrix A .

The rest of this section will give some known results on directed strongly regular graphs which we will require later.

2.1 Lemma. (Duval, [2]) *For a directed strongly regular graph with parameters (v, k, t, λ, μ) ,*

$$0 \leq \lambda < t \tag{2.3}$$

$$0 < \mu \leq t \tag{2.4}$$

The fact that $\mu > 0$ means that the matrix equations give enough information to calculate the eigenvalues of A .

2.2 Theorem. (Duval, [2]) *Let A be the adjacency matrix of a directed strongly regular graph with parameters (v, k, t, λ, μ) . Then A has eigenvalues $\theta_0 = k$, $\theta_1 = \frac{1}{2}(\lambda - \mu + \delta)$, $\theta_2 = \frac{1}{2}(\lambda - \mu - \delta)$ with multiplicities $m_0 = 1$, $m_1 = -\frac{k + \theta_2(v-1)}{\theta_2 - \theta_1}$ and $m_2 = \frac{k + \theta_1(v-1)}{\theta_2 - \theta_1}$ respectively, where $\delta = \sqrt{(\mu - \lambda)^2 + 4(t - \mu)}$ is a positive integer.*

Duval [2] gave a list of feasible parameter sets with $v \leq 20$ which pass all parameter conditions given in that paper. This list has been extended to $v \leq 110$ by Hobart and Brouwer and is available on the web [1], with notes giving the current knowledge about existence.

3 Representations

We will require some further results about the eigenspaces of A .

3.1 Proposition. *Let A be the adjacency matrix of a directed strongly regular graph with parameters (v, k, t, λ, μ) . Then*

- (a) *A is diagonalizable but not normal.*
- (b) *Suppose that z is any eigenvector for θ_1 or θ_2 . Then $z \perp \mathbf{1}$, where $\mathbf{1}$ is the all 1's vector.*

Proof. The definition of directed strongly regular graph implies that A has minimum polynomial of degree 3, namely

$$(A - kI)(A^2 + (\mu - \lambda)A + (\mu - t)I) = 0.$$

Since $d > 0$, A has three distinct eigenvalues, and hence A is diagonalizable. Since A is a real matrix with real eigenvalues which is not symmetric, it cannot be normal.

Suppose that z is a right eigenvector for θ_i . Then

$$kJz = JAz = \theta_i Jz$$

with $k \neq \theta_i$, and therefore $Jz = 0$. The same argument applies to left eigenvectors. \square

The fact that A is diagonalizable will allow us to map vertices to vectors in \mathbb{R}^m , where m is one of the multiplicities, in much the same manner as a representation of a graph (see, eg., [5], Chapter 13). The difference is that each vertex maps to a pair of vectors.

Since A is diagonalizable, there exists an invertible matrix P such that $A = PDP^{-1}$, where

$$D = \text{diag}(\theta_0, \theta_1, \dots, \theta_1, \theta_2, \dots, \theta_2)$$

and P has the form

$$P = (X_0 \ X_1 \ X_2)$$

such that $X_0 = \mathbf{1}$ and the columns of X_i form a basis for the right eigenspace corresponding to θ_i .

Let matrices $Y_0 = \mathbf{1}$, Y_1, Y_2 be defined so that

$$P^{-1} = \begin{pmatrix} \frac{m_0}{v}Y_0 & \frac{m_1}{v}Y_1 & \frac{m_2}{v}Y_2 \end{pmatrix}^T.$$

Since $P^{-1}P = I$, we see that $Y_i^T X_i = (v/m_i)I$ and $Y_i^T X_j = 0$ for $i \neq j$. In addition, it is clear that the columns of Y_i form a basis for the left eigenspace of A corresponding to θ_i .

Let $E_i = (m_i/v)X_i Y_i^T$. Clearly $E_i^2 = E_i$, and the column space of E_i is the right eigenspace corresponding to θ_i , so E_i is a projection onto this space. The projections E_i have many of the same properties as they do in the graph case, but $E_i^T \neq E_i$ unless $i = 0$.

3.2 Proposition.

(a) $E_i E_j = \delta_{ij} E_i$

(b) E_i is a projection onto the eigenspace corresponding to θ_i .

(c) $A = \theta_0 E_0 + \theta_1 E_1 + \theta_2 E_2$

(d) $I = E_0 + E_1 + E_2$

Proof. We have already shown (1) and (2). The equations (3) and (4) follow from $A = PDP^{-1}$ and the definitions of E_0, E_1, E_2 . \square

Fix an eigenvalue $\theta = \theta_i \in \{\theta_1, \theta_2\}$ and let τ be the remaining eigenvalue in this set. Let $E = E_i$, $X = X_i$, $Y = Y_i$, and $m = m_i$. Let x_j be the j^{th} row of X , and y_j the j^{th} row of Y . Then the maps $j \mapsto x_j$ and $j \mapsto y_j$ are a pair of maps from $V(G)$ to \mathbb{R}^m ; since $AX = \theta X$ and $Y^T A = \theta Y^T$, these maps satisfy

$$\sum_{j \rightarrow h} x_h = \theta x_j \quad \text{and} \quad \sum_{h \rightarrow j} y_h = \theta y_j.$$

We will refer to these maps as the left and right *representations* (respectively) of Γ on the eigenspaces corresponding to θ .

Example: The smallest directed strongly regular graph has parameters $(6,2,1,0,1)$ and its adjacency matrix has eigenvalues 2, 0 and -1 . For $\theta = -1$, we have $m = 2$ and

$$X^T = \begin{bmatrix} 0 & 1 & -1 & -1 & 0 & 1 \\ 1 & 0 & -1 & -1 & 1 & 0 \end{bmatrix}, Y^T = \begin{bmatrix} 1 & 1 & -2 & 1 & -2 & 1 \\ 1 & -2 & 1 & -2 & 1 & 1 \end{bmatrix}.$$

The left and right representations given by these are depicted in Figure 1. \square

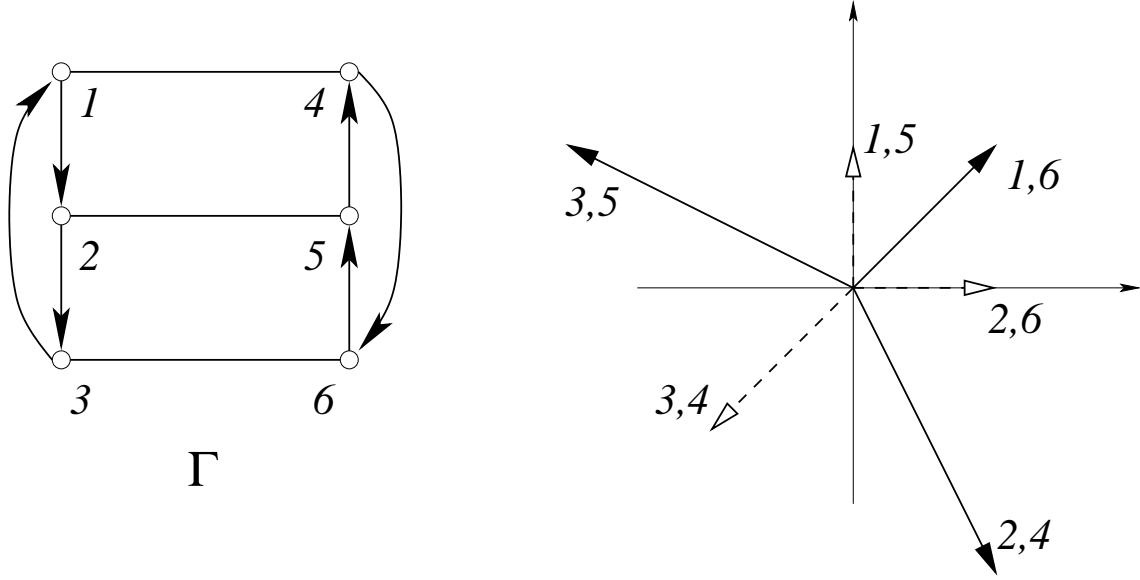

Figure 1: Eigenspace representation of $\text{dsrg}(6, 2, 1, 0, 1)$ is not injective. Left representation y_j of a vertex j is solid while x_j is hollow/dashed.

The matrices E_0, E_1, E_2 span a 3-dimensional subalgebra of $M_v(\mathbb{R})$ which contains I and A , and it follows that $\langle E_0, E_1, E_2 \rangle = \langle I, A, J - I - A \rangle$. Since E is a projection, $\text{tr}(E) = \text{rk}(E) = m$, and so

$$E = \frac{m}{v} (I + \alpha A + \beta (J - A - I)) \quad (3.1)$$

for some $\alpha, \beta \in \mathbb{R}$.

If $\alpha = \beta$, then $E = \frac{m}{v} (I + \alpha (J - I))$ has rank 1, $v - 1$, or v . But $\text{rk}(E) = m < v - 1$. If $\text{rk}(E) = 1$, then $\alpha = \beta = 1$ and $E = (m/v)J$ contradicting $EE_0 = 0$. Therefore, $\alpha \neq \beta$.

We can determine α and β in terms of the parameters of the directed strongly regular graph.

3.3 Proposition.

$$\alpha = \frac{\lambda - k - \tau}{t + k\tau} \quad (3.2)$$

$$\beta = \frac{\mu}{t + k\tau} \quad (3.3)$$

Proof. Let

$$f(x) = \frac{(x - k)(x - \tau)}{(\theta - k)(\theta - \tau)}.$$

Clearly $f(A) = E$, since they agree on the basis of eigenvectors.

But we can also calculate directly:

$$\begin{aligned} f(A) &= \frac{1}{(\theta - k)(\theta - \tau)} (A^2 - (k + \tau)A + k\tau I) \\ &= \frac{1}{(\theta - k)(\theta - \tau)} ((t + k\tau)I + (\lambda - k - \tau)A + \mu(J - I - A)) \end{aligned}$$

By (3.1), this implies that

$$\begin{aligned} \frac{m}{v} &= \frac{t + k\tau}{(\theta - k)(\theta - \tau)} \\ \frac{m}{v}\alpha &= \frac{\lambda - k - \tau}{(\theta - k)(\theta - \tau)} \\ \frac{m}{v}\beta &= \frac{\mu}{(\theta - k)(\theta - \tau)} \quad \square \end{aligned}$$

Since $E = \frac{m}{v}XY^T$, we have $XY^T = I + \alpha A + \beta(J - I - A)$. The (i, j) entry of this matrix is the inner product $\langle x_i, y_j \rangle$, and it follows that

$$\langle x_i, y_j \rangle = \begin{cases} 1, & \text{if } i = j; \\ \alpha, & \text{if } i \rightarrow j; \\ \beta, & \text{otherwise} \end{cases} \quad (3.4)$$

We want to use the representations to give information about Γ .

We say that the right representation X is *injective* if $x_i = x_j$ implies that $i = j$; and similarly for the left representation Y . The following theorem gives a sufficient condition for injectivity.

3.4 Theorem. *Suppose $\alpha, \beta \neq 1$. Then both X and Y are injective.*

Proof. Suppose $x_i = x_j$ for some $i \neq j$.

Then $1 = \langle x_i, y_i \rangle = \langle x_j, y_i \rangle = \alpha$ or β as $j \rightarrow i$ or $j \not\rightarrow i$, and hence either $\alpha = 1$ or $\beta = 1$.

The proof for Y is similar. □

Any eigenvector of A is also an eigenvector of E ; the corresponding eigenvalues are 0, 0, and 1. The following equations are the result of using (3.1) and these eigenvectors.

$$0 = 1 + \alpha k + \beta(v - k - 1) \tag{3.5}$$

$$0 = 1 + \alpha\tau + \beta(-\tau - 1) \tag{3.6}$$

$$\frac{v}{m} = 1 + \alpha\theta + \beta(-\theta - 1) \tag{3.7}$$

3.5 Lemma.

(a) $\alpha = 1$ if and only if $\tau = -1$;

(b) $\beta = 1$ if and only if $\tau = 0$.

Proof. Equation (3.6) implies that $1 + \alpha\tau - \beta - \beta\tau = 0$, and the results follow since $\alpha \neq \beta$. □

3.6 Corollary. *Suppose $\tau \neq 0, -1$. Then X and Y are injective.*

The converse is not true. The smallest directed strongly regular graph, with parameters $(6, 2, 1, 0, 1)$ provides a counterexample. Both left and right representations for eigenvalue 0 are injective, but $\beta = 1$.

The reverse of Γ is the directed graph Γ^T with matrix A^T . It is also a directed strongly regular graph, with the same parameters as Γ . This is useful because the transpose map interchanges the roles of X and Y . If one of the representations is not injective, we can assume without loss of generality that it is X .

The complement of Γ is the directed graph Γ^c with matrix $A^c = J - I - A$; it is a directed strongly regular graph, with parameters $(v, v - k - 1, v - 2k + t - 1, v - 2k + \mu - 2, v - 2k + \lambda)$ and eigenvalues $v - k + 1, -\theta_1 - 1, -\theta_2 - 1$, and the same projections E_0, E_1, E_2 . It is clear from the matrix equation (3.1) that taking the complement of Γ interchanges α and β . This will be helpful in establishing properties of α and β . Note that Γ has eigenvalue -1 if and only if Γ^c has eigenvalue 0. Thus if either X or Y is not injective, we can assume that $\tau = -1$ and $\alpha = 1$.

We will require a few more straightforward results about the values of α and β .

3.7 Proposition.

- (a) $\alpha \neq 0$ and $\beta \neq 0$.
- (b) One of α and β is positive and the other is negative.
- (c) If $\beta > 0$, then $\tau \geq 0$.
If $\beta < 0$, then $\tau < 0$.
- (d) $\alpha, \beta \leq 1$.

Proof.

(a) Recall from (3.3) that $\beta = \mu/(t + k\tau)$. By (2.4), $\mu > 0$, hence $\beta \neq 0$. Considering the complement, this implies that $\alpha \neq 0$.

(b) This follows from equation (3.5).

(c) Assume that $\beta > 0$, so $\alpha < 0$. By equation (3.7),

$$\theta = \frac{\frac{v}{m} - 1 + \beta}{\alpha - \beta}.$$

Since $v > m$, this implies that $\theta < 0$, and hence that $\tau \geq 0$.

(d) Suppose $\beta > 0$, so $\tau \geq 0$. By (2.4), $\mu \leq t \leq t + k\tau$, hence $\beta \leq 1$. Considering the complement of Γ , one obtains the result for α . \square

3.8 Corollary.

$$(1 - \alpha)(1 - \beta) \neq v\alpha\beta$$

Proof. If $\beta < 0$, then $0 \leq \alpha \leq 1$. This means that $(1 - \alpha)(1 - \beta) \geq 0$, while $v\alpha\beta < 0$. The case $\alpha < 0$ is similar. \square

4 Bounds on v for $\tau \neq 0, -1$

Recall that Γ is a $\text{dsrg}(v, k, t, \lambda, \mu)$ with nontrivial eigenvalues θ and τ and we are considering the representations X and Y on the right and left eigenspaces corresponding to θ where $E = E_\theta = \frac{m}{v}XY^T$ is written $E = \frac{m}{v}(I + \alpha A + \beta(J - A - I))$.

If $\tau \neq 0, -1$, then we can use these representations to bound v . The proof requires the following lemma.

4.1 Lemma. For a directed strongly regular graph such that $\tau \neq 0, -1$, $(\alpha^2 - \beta^2)\tau \neq \beta^2 - 1$.

Proof. Suppose $\alpha^2 - \beta^2 = 0$. Since $\alpha \neq 1$, $\beta^2 - 1 \neq 0$ and so the inequality holds.

Now assume that $\alpha^2 - \beta^2 \neq 0$. Equation (3.6) implies that

$$\tau = \frac{\beta - 1}{\alpha - \beta}.$$

If

$$\tau = \frac{\beta^2 - 1}{\alpha^2 - \beta^2},$$

then

$$\frac{\beta + 1}{\alpha + \beta} = 1$$

which implies that $\alpha = 1$, a contradiction. \square

4.2 Theorem. ([8], Theorem 2) Suppose Γ is a directed strongly regular graph with $\tau \neq 0, -1$. Then

(a) $v \leq \frac{m(m+3)}{2}$.

(b) If $(\alpha^2 - \beta^2)\theta \neq \beta^2 - 1$, then $v \leq \binom{m+1}{2}$.

Proof. We have two sets of v vectors $\{x_1, \dots, x_v\}$ and $\{y_1, \dots, y_v\}$ in \mathbb{R}^m such that the inner products are given by (3.4). For any polynomial $f(\xi) \in \mathbb{R}[\xi]$ and any $y \in \mathbb{R}^m$, define $f_y \in \mathbb{R}[z_1, \dots, z_m]$ by $f_y(z) = f(\langle y, z \rangle)$. Note that $\deg(f_y) = \deg(f)$.

We want to choose f in such a way that f_{y_1}, \dots, f_{y_v} are linearly independent.

For any $f \in \mathbb{R}[\xi]$, let M_f be the matrix whose (i, j) entry is $f(\langle x_i, y_j \rangle)$. Then

$$M_f = f(1)I + f(\alpha)A + f(\beta)(J - I - A).$$

Suppose that $\sum c_i f_{y_i} = 0$. This gives a system of linear equations with coefficient matrix M_f . If all eigenvalues of M_f are nonzero, then f_{y_1}, \dots, f_{y_v} are linearly independent; and these eigenvalues are easily calculated using the eigenvalues of the commuting matrices I , J , and A .

Let $f(\xi) = \xi^2 - (\alpha + \beta)\xi$. Then $M_f = (1 - \alpha - \beta)I - \alpha\beta(J - I)$, with eigenvalues $(1 - \alpha)(1 - \beta)$ and $(1 - \alpha)(1 - \beta) - \alpha\beta v$. These are nonzero by

the assumption on τ and Lemmas 3.5 and 4.1. Therefore, f_{y_1}, \dots, f_{y_v} are linearly independent.

Each of the polynomials f_{y_i} has degree at most 2 and zero constant term. The subspace of $\mathbb{R}[z_1, \dots, z_m]$ consisting of polynomials with these properties has dimension $\binom{m+2}{2} - 1 = \frac{m(m+3)}{2}$, hence $v \leq \frac{m(m+3)}{2}$.

Now let $f(\xi) = \xi^2$. Then $M_f = I + \alpha^2 A + \beta^2(J - I - A)$, with eigenvalues $1 + \alpha^2 k + \beta^2(v - k - 1)$ which is clearly greater than 0, $1 + \alpha^2 \theta + \beta^2(-1 - \theta)$ which is nonzero by Lemma 4.1, and $1 + \alpha^2 \tau + \beta^2(-1 - \tau)$ which is nonzero by hypothesis. Therefore, f_{y_1}, \dots, f_{y_v} are linearly independent.

Each of the polynomials f_{y_i} is homogeneous of degree 2. Therefore, $v \leq \binom{m+1}{2}$, the dimension of the corresponding subspace of $\mathbb{R}[z_1, \dots, z_m]$. \square

It follows from (3.1) that Jørgensen's parameter $q_\theta^{\theta\theta}$ is given by $q_\theta^{\theta\theta} = 1 + \alpha^2 \theta + \beta^2(-1 - \theta)$, and so this is precisely the same result as [8].

This bound rules out the feasible parameter set $(80, 31, 24, 7, 15)$, for example.

5 Noninjective Representations

If we do not assume that X is injective, we can still use the representation to get some information about the graph. In particular we can completely determine the graphs with an eigenvalue of multiplicity 2. These results were independently found by Jørgensen ([8], theorems 3, 4, and 5), using different methods.

Suppose X has d distinct rows, which we write as r_1, \dots, r_d . There are some fairly simple bounds on d in terms of m .

Note that if $m = 2$ and τ is not 0 or -1 , then by Theorem 4.2, $v \leq 5$. The smallest directed strongly regular graph has $v = 6$, thus no such directed strongly regular graph exists.

If τ is 0 or -1 , then either α or β is 1. In fact our arguments are based on this and not whether or not the representations are injective. Throughout this section, we will assume that $\alpha = 1$ and hence $\tau = -1$.

5.1 Theorem. $m + 1 \leq d \leq 2^m$

Proof. Let s_1, \dots, s_m be rows of Y which form a basis for \mathbb{R}^m ; these exist since Y has rank m . For all r_i , $\langle r_i, s_j \rangle = 1$ or β . This implies that given j , all r_i lie in one of the two affine hyperplanes

$$\pi_j(1) = \{z : \langle z, s_j \rangle = 1\}$$

and

$$\pi_j(\beta) = \{z : \langle z, s_j \rangle = \beta\}$$

which are parallel to s_j^\perp .

Since $\{s_1, \dots, s_m\}$ spans \mathbb{R}^m ,

$$\bigcap_j s_j^\perp = \{0\}.$$

It follows that

$$\bigcap_{j=1}^m (\pi_j(1) \cup \pi_j(\beta))$$

is a set of cardinality at most 2^m which contains r_1, \dots, r_d .

On the other hand, $\{r_1, \dots, r_d\}$ spans \mathbb{R}^m , so $d \geq m$. The columns of X are eigenvectors of A corresponding to θ , hence are orthogonal to $\mathbf{1}$ and $\mathbf{1}^T X = 0$. This gives a nontrivial dependence relation on the vectors r_1, \dots, r_d , so $d > m$. \square

Let $C_a = \{j : x_j = r_a\}$. The sets C_a determine a lot of the structure of Γ . Suppose $i, j \in C_a$. Then $x_i = x_j$, so $1 = \langle x_i, y_i \rangle = \langle x_j, y_i \rangle$ and this means that $j \rightarrow i$. Therefore C_a is a clique in Γ .

Suppose $i \in C_a$, and $i \rightarrow l \notin C_a$. Then for all $j \in C_a$, $\langle x_j, y_l \rangle = \langle x_i, y_l \rangle = 1$, hence $j \rightarrow l$. In this case, we will write $C_a \rightarrow l$.

Assume that $m = 2$. By the previous theorem, d is 3 or 4. This will give us enough information to determine all such directed strongly regular graphs, up to isomorphism and complementation. The constructions of the relevant graphs are given in Section 5.1.

5.2 Theorem. *Suppose Γ is directed strongly regular graph with eigenvalue $\tau = -1$ such that the representation corresponding to θ has $m = 2$ and $d = 3$. Then Γ has parameters $v = 6c$, $k = 4c - 1$, $t = 3c - 1$, $\lambda = 3c - 2$, and $\mu = 2c$ for some integer c , and Γ is isomorphic to one of the graphs of Corollary 6.3 with $n=3$.*

Proof. There are three sets C_1, C_2, C_3 defined as above which are cliques in Γ . If $i \in C_1$, then since $k < v - 1$ we cannot have both $C_2 \rightarrow i$ and $C_3 \rightarrow i$. If $C_2 \not\rightarrow i$ and $C_3 \not\rightarrow i$, then all edges pointing to i are from vertices of C_1 , and hence are undirected. But this would imply that $k = t$, a contradiction. Therefore either $C_2 \rightarrow i$ or $C_3 \rightarrow i$, but not both. A similar result holds for vertices of C_2 and C_3 .

Let $C_{ab} = \{i \in C_a : C_b \rightarrow i\}$, for $a \neq b$. Then the sets C_{ab} partition C_a . Let $c_{ab} = |C_{ab}|$ and $c_a = |C_a|$.

Considering in-degrees, it is easy to see that $c_1 = c_2 = c_3$.

The number of 2-paths from a vertex of C_1 to a vertex of C_{21} is $\lambda = c_1 + c_{21} - 2$; from a vertex of C_1 to a vertex of C_{31} , it is $\lambda = c_1 + c_{31} - 2$. Therefore $c_{21} = c_{31}$. Similarly we find that c_{ab} is a constant c , and then $c_i = 2c$. Now the parameters of the graph are easily calculated.

It is clear that the structure of Γ is completely determined (up to isomorphism), and that they are the graphs of Corollary 6.3 with $n = 3$ and $C_{a,b} = \{(a, b, l) : 1 \leq l \leq c\}$. \square

5.3 Theorem. *Suppose Γ is a directed strongly regular graph with eigenvalue -1 such that the representation corresponding to θ has $m = 2$ and $d = 4$. Then Γ has parameters $v = 8c$, $k = 4c - 1$, $t = 3c - 1$, $\lambda = 3c - 2$, and $\mu = c$ for some integer c , and Γ is isomorphic to one of the graphs of Corollary 6.6 with $n=2$.*

Proof. There are four nonempty sets C_1, C_2, C_3, C_4 which are cliques in Γ . We can order the vectors so that $C_1 = \{i : \langle x_i, y_1 \rangle = 1, \langle x_i, y_2 \rangle = 1\}$, $C_2 = \{i : \langle x_i, y_1 \rangle = \beta, \langle x_i, y_2 \rangle = 1\}$, $C_3 = \{i : \langle x_i, y_1 \rangle = 1, \langle x_i, y_2 \rangle = \beta\}$, and $C_4 = \{i : \langle x_i, y_1 \rangle = \beta, \langle x_i, y_2 \rangle = \beta\}$, where y_1 and y_2 are linearly independent. Geometrically, we have a parallelogram whose vertices are the vectors r_1, r_2, r_4, r_3 (moving clockwise around the parallelogram).

If there exists $i \in C_1$ and $j \in C_4$ such that $i \rightarrow j$, then $\langle x_i, y_j \rangle = 1$ and $\langle x_j, y_j \rangle = 1$. This means that the line $\{x : \langle x, y_j \rangle = 1\}$ contains the points r_1 and r_4 . But then the parallel line $\{x : \langle x, y_j \rangle = \beta\}$ must contain r_2 and r_3 , which is impossible since they are diagonals of the parallelogram. Therefore $C_1 \not\rightarrow C_4$, that is, no vertex in C_1 points to any vertex of C_4 . Similarly $C_4 \not\rightarrow C_1$, $C_2 \not\rightarrow C_3$, and $C_3 \not\rightarrow C_2$. This also shows that there is no y_i such that $\{x : \langle x, y_i \rangle = 1\}$ or $\{x : \langle x, y_i \rangle = \beta\}$ contains opposite vertices of the parallelogram.

Suppose there exists $i \in C_1$ such that $C_2 \rightarrow i$ and $C_3 \rightarrow i$. Let $j \in C_2$ and $l \in C_3$. Then $\langle x_j, y_i \rangle = \langle x_l, y_i \rangle = 1$, so the line $\{x : \langle x, y_i \rangle = 1\}$ contains the opposite points r_2 and r_3 , a contradiction. On the other hand if there exists $i \in C_1$ such that $C_2 \not\rightarrow i$, $C_3 \not\rightarrow i$, then all edges containing i are undirected and $k = t$, a contradiction. Therefore for any $i \in C_1$, either $C_2 \rightarrow i$ or $C_3 \rightarrow i$, but not both. Hence we can partition C_1 into $C_{12} \cup C_{13}$, as in the $d = 3$ case. Similarly $C_2 = C_{21} \cup C_{24}$, $C_3 = C_{31} \cup C_{34}$, and $C_4 = C_{42} \cup C_{43}$.

Let $c_{ab} = |C_{ab}|$, and $c_a = |C_a|$. Checking in-degrees, it is easy to see that $c_1 = c_2 = c_3 = c_4$.

We will also show that the c_{ab} 's are constant.

Comparing the number of 2-paths from a vertex of C_1 to a vertex of C_{21} , to the number of 2-paths from a vertex of C_1 to a vertex of C_{31} , we find that $c_{21} = c_{31}$, which implies that $c_{24} = c_{34}$. Similarly counting the number of 2-paths from C_2 to C_{12} , and from C_2 to C_{42} shows that $c_{12} = c_{42}$ and $c_{13} = c_{43}$.

Now using these equations and comparing out-degrees shows that all c_{ab} 's are a constant c .

It is clear that the structure of these graphs is completely determined (up to isomorphism), and that they are the graphs of Corollary 6.6 with $n = 2$ and $q = 2$. \square

This completely determines the directed strongly regular graphs with $m = 2$. It also shows that each such graph is isomorphic to its reverse. In terms of parameters, we have the following.

5.4 Corollary. *Suppose Γ is a directed strongly regular graph with a representation of multiplicity 2. Then Γ or its complement has parameters either*

$$v = 6c \quad k = 4c - 1 \quad t = 3c - 1 \quad \lambda = 3c - 2 \quad \mu = 2c$$

or

$$v = 8c \quad k = 4c - 1 \quad t = 3c - 1 \quad \lambda = 3c - 2 \quad \mu = c$$

for some integer c .

This rules out for example the feasible parameter sets $(25, 10, 6, 1, 6)$ and $(54, 24, 16, 4, 16)$.

6 Constructions

In this section, we will describe a number of constructions for directed strongly regular graphs. Some of these give graphs with eigenvalue $\tau = -1$; this is equivalent to $\alpha = 1$. From (3.2) these values imply that $\lambda = t - 1$ and we can then apply a construction of Duval.

6.1 Theorem. ([2], Theorem 7.2) *Suppose that Γ is a directed strongly regular graph with parameters (v, k, t, λ, μ) where $\lambda = t - 1$, and w is a positive integer. Then there exists a directed strongly regular graph with parameters $(vw, (k + 1)w - 1, (t + 1)w - 1, (t + 1)w - 2, \mu w)$.*

6.1 Geometric constructions

The proofs of theorems 5.2 and 5.3 construct the graphs (and thereby show uniqueness). These proofs suggest generalizations of the constructions which are essentially geometric; these are given below in Corollary 6.3 and Theorem 6.5. Note that the first three constructions are not new; the graphs of Theorems 6.2 and 6.4 are isomorphic to certain cases of [4], Theorem 5.6(2), and the graphs of Corollary 6.3 follow from them.

6.2 Theorem. *Let $n \geq 3$ be an integer. Let Γ be the directed graph with vertex set $V = \{(i, j) : 1 \leq i, j \leq n, i \neq j\}$, and directed edges given by $(i, j) \rightarrow (a, b)$ if $a = j$, or $a = i$ and $b \neq j$.*

Then Γ is a directed strongly regular graph with parameters $v = n(n - 1)$, $k = 2n - 3$, $t = n - 1$, $\lambda = n - 2$, and $\mu = 2$. It has eigenvalues k , $n - 3$ and -1 with multiplicities 1 , $n - 1$ and $n(n - 2)$ respectively.

Proof. Use counting arguments. □

The graphs of the previous theorem have $\lambda = t - 1$, so we may apply Theorem (6.1).

6.3 Corollary. *For any $n \geq 3$, $w \geq 1$, there exists a directed strongly regular graph with parameters $v = wn(n - 1)$, $k = w(2n - 2) - 1$, $t = wn - 1$, $\lambda = wn - 2$, and $\mu = 2w$. This may be constructed as follows. Let $V = \{(i, j, l) : 1 \leq i, j \leq n, i \neq j, 1 \leq l \leq w\}$, and directed edges given by $(i, j, l) \rightarrow (a, b, c)$ if $a = j$, or $a = i$ and $b \neq j$. It has eigenvalues k , $w(n - 2) - 1$ and -1 with multiplicities 1 , $n - 1$ and $n(wn - w - 1)$ respectively.*

There is a q -analogue of this construction, which also gives a directed strongly regular graph. As usual, we write $\begin{bmatrix} n \\ k \end{bmatrix}$ for the q -ary Gaussian binomial coefficient; that is,

$$\begin{bmatrix} n \\ k \end{bmatrix} = \frac{(q^n - 1) \dots (q^{n-k+1} - 1)}{(q^k - 1) \dots (q - 1)}.$$

6.4 Theorem. *Let q be a prime power, and $n \geq 2$. Define Γ to be the directed graph with vertex set*

$$V = \{(x, \pi) : x \in PG(n, q), \pi \text{ a line of } PG(n, q), x \in \pi\},$$

and directed edges given by $(x_1, \pi_1) \rightarrow (x_2, \pi_2)$ if $x_2 \in \pi_1$ and $(x_1, \pi_1) \neq (x_2, \pi_2)$.

Then Γ is a directed strongly regular graph with parameters $v = q \begin{bmatrix} n \\ 2 \end{bmatrix}$, $k = (q+1) \begin{bmatrix} n-1 \\ 1 \end{bmatrix} - 1$, $t = \begin{bmatrix} n-1 \\ 1 \end{bmatrix} + q - 1$, $\lambda = \begin{bmatrix} n-1 \\ 1 \end{bmatrix} + q - 2$, and $\mu = q + 1$. It has eigenvalues k , $\begin{bmatrix} n-1 \\ 1 \end{bmatrix} - 2$ and -1 with multiplicities 1 , $q \begin{bmatrix} n-1 \\ 1 \end{bmatrix}$ and $q \begin{bmatrix} n \\ 1 \end{bmatrix} \begin{bmatrix} n-2 \\ 1 \end{bmatrix}$ respectively.

6.5 Theorem. *Let $n, q \geq 2$ be integers, and Q be a set of order q . Define Γ to be the directed graph with vertex set $V = Q^n \times \{1, \dots, n\}$ and directed edges given by $(a, i) \rightarrow (b, j)$ if $a_i = b_i$ and $(a, i) \neq (b, j)$.*

Then Γ is a directed strongly regular graph with parameters $v = nq^n$, $k = nq^{n-1} - 1$, $t = (q + n - 1)q^{n-2} - 1$, $\lambda = (q + n - 1)q^{n-2} - 2$, and $\mu = (n - 1)q^{n-2}$. It has eigenvalues k , $q^{n-1} - 1$ and -1 with multiplicities 1 , $n(q - 1)$ and $n(q^n - q + 1) - 1$ respectively.

Proof. Easy counting arguments give the values for v , k , and t .

Suppose $(a, i) \not\rightarrow (b, j)$. We want to count the number of (c, l) such that $(a, i) \rightarrow (c, l) \rightarrow (b, j)$. We must have $l \neq i$ since $a_i \neq b_i$, so there are $n - 1$ choices for l . Once l is chosen, we must choose c so that $c_i = a_i$ and $c_l = b_l$; hence there are q^{n-1} choices for c , and $\mu = (n - 1)q^{n-2}$.

Suppose $(a, i) \rightarrow (b, j)$. We want to count the number of (c, l) such that $(a, i) \rightarrow (c, l) \rightarrow (b, j)$. If we choose $l = i$, then c must satisfy $c_i = a_i$ (which equals b_i), and there are $q^{n-1} - 1$ such $c \neq a$. On the other hand, if $l \neq i$, then c must satisfy $c_i = a_i$ and $c_l = b_l$ and there are q^{n-1} such c ; but we must subtract 1 for the choice $l = j$, $c = b$. Therefore, $\lambda = q^{n-1} - 1 + (n - 1)q^{n-2} - 1$. \square

If $q = 2$ and $Q = \{0, 1\}$, there is an obvious map from V to \mathbb{R}^n given by $(a, i) \rightarrow a$. We can adapt this to give a representation. Define

$$y_{(a,i)} = a - \left(\frac{n2^{n-1} - 1}{(n-1)2^{n-2}} \right) \mathbf{1}.$$

Then it can be shown that the map $(a, i) \rightarrow y_{(a,i)}$ is a right representation corresponding to the eigenvalue $2^{n-1} - 1$. Clearly this representation is not injective, which is not surprising since $\tau = -1$.

The smallest new graph given by this construction has parameters $(375, 74, 10, 33, 34)$.

We can again apply Theorem 6.1 to the graphs of Theorem 6.5.

6.6 Corollary. *Let $n, q \geq 2$, and $w \geq 1$ be integers. Then there exists a directed strongly regular graph with parameters $v = wnq^n$, $k = wnq^{n-1} - 1$, $t = w(q + n - 1)q^{n-2} - 1$, $\lambda = w(q + n - 1)q^{n-2} - 2$, and $\mu = w(n - 1)q^{n-2}$. It has eigenvalues k , $wq^{n-1} - 1$ and -1 with multiplicities 1 , $n(q - 1)$ and $n(wq^n - q + 1) - 1$ respectively.*

These graphs can be explicitly described. Define Γ to be the directed graph with vertex set $V = Q^n \times \{1, \dots, n\} \times \{1, \dots, w\}$ and directed edges given by $(a, i_1, i_2) \rightarrow (b, j_1, j_2)$ if $a_{i_1} = b_{i_1}$ and $(a, i_1, i_2) \neq (b, j_1, j_2)$.

6.2 Tensor constructions

6.7 Theorem. *Let Γ be a directed strongly regular graph with parameters (v, k, t, λ, μ) such that $\mu = \lambda$ and $v = 4k - 4\mu$. Suppose there exists a $c \times c$ $(1, -1)$ matrix H with 1's on the diagonal such that $HJ = JH = dJ$ and $H^2 = cI$. Then there exists a directed strongly regular graph with parameters $(\bar{v}, \bar{k}, \bar{t}, \bar{\lambda}, \bar{\mu})$ where $\bar{\lambda} = \bar{\mu}$, $\bar{v} = 4\bar{k} - 4\bar{\mu}$, and*

$$\begin{aligned} \bar{v} &= vc \\ \bar{k} &= c(2k - 2\mu) + d(2\mu - k) \\ \bar{t} &= c(k + t - 2\mu) + d(2\mu - k) \\ \bar{\lambda} = \bar{\mu} &= c(k - \mu) + d(2\mu - k) \end{aligned}$$

Proof. Let A be the adjacency matrix of Γ and $B = 2A - J$. Then B is a $(-1, 1)$ matrix with (-1) 's on the diagonal. The assumptions on the parameters of Γ imply that

$$B^2 = 4(t - \mu)I + 4(\lambda - \mu)A + (v - 4\mu - 4k)J = 4(t - \mu)I$$

and

$$BJ = JB = (2k - v)J.$$

We will use this to construct a larger matrix with the same properties. Let $\overline{B} = B \otimes H$; then \overline{B} is also a $(-1, 1)$ matrix with (-1) 's on the diagonal. We can easily calculate

$$\begin{aligned}\overline{B}J &= J\overline{B} = d(2k - v)J = d(4\mu - 2k)J \\ \overline{B}^2 &= 4c(t - \mu)I\end{aligned}$$

where J and I are now $vc \times vc$ matrices.

The graph corresponding to the matrix \overline{B} will be the new directed strongly regular graph Γ . To show this, we undo the above process to get the adjacency matrix. Let

$$\overline{A} = \frac{\overline{B} + J}{2}.$$

Then

$$\begin{aligned}\overline{A}J &= J\overline{A} \\ &= \frac{1}{2}(d(2k - v) + vw)J \\ &= \frac{1}{2}(d(4\mu - 2k) + c(4k - 4\mu))J \\ &= (d(2\mu - k) + w(2k - 2\mu))J\end{aligned}$$

and

$$\begin{aligned}\overline{A}^2 &= \frac{1}{4}(\overline{B}^2 + 2\overline{B}J + J^2) \\ &= \frac{1}{4}(4c(t - \mu)I + 2d(4\mu - 2k)J + w(4k - 4\mu)J) \\ &= (c(t - \mu)I + (d(2\mu - k) + w(k - \mu))J).\end{aligned}$$

□

Note that H must be a regular Hadamard matrix with constant diagonal. This implies that $c = 4s^2$ for some integer s , and $d = 2s$.

For example, let

$$H = \begin{pmatrix} 1 & -1 & 1 & 1 \\ -1 & 1 & 1 & 1 \\ 1 & 1 & 1 & -1 \\ 1 & 1 & -1 & 1 \end{pmatrix}$$

which has $c = 4$ and $d = 2$. There exists a directed strongly regular graph Γ with parameters $(8, 3, 2, 1, 1)$. Then $\bar{\Gamma}$ is a directed strongly regular graph with parameters $(32, 14, 10, 6, 6)$ which is new.

6.3 Matrix constructions

There are some simple constructions of directed strongly regular graphs using matrix products which give new examples. These graphs all have 0 as an eigenvalue.

6.8 Theorem. *Let B_1, \dots, B_q be $n \times n$ $(0, 1)$ matrices satisfying the following conditions.*

- (a) *There is a constant c such that each B_i has constant row sum c .*
- (b) *B_i has 0's on the diagonal, for all i .*
- (c) *$\sum_{i=1}^q B_i = d(J - I)$ for some integer d .*

Then $A = \begin{pmatrix} B_1 \\ \vdots \\ B_q \end{pmatrix} (I \ \dots \ I)$ is the adjacency matrix of a directed strongly regular graph with parameters $v = nq$, $k = cq$, $t = cd$, $\lambda = cd - d$, $\mu = cd$.

Proof. Calculating using properties (a) to (c), we find that $A^2 = cdJ - dA$. \square

Note that if the conditions are satisfied, then taking row sums on either side of the equation in (c) implies that $qc = d(n - 1)$. It is thus a necessary condition that $c|d(n - 1)$; in fact, this condition is also sufficient.

6.9 Corollary. *Suppose n , d , and c are positive integers such that $c < n - 1$ and $c|d(n - 1)$. Then there exists a directed strongly regular graph with parameters $v = dn(n - 1)/c$, $k = d(n - 1)$, $t = cd$, $\lambda = cd - d$, and $\mu = cd$.*

Proof. Let C be the $n \times n$ circulant with first row $(0 \ 1 \ 0 \ \dots \ 0)$. Note that

$$C^n = I,$$

and

$$\sum_{i=1}^{n-1} C^i = J - I.$$

Let $q = d(n - 1)/c$.

Then we can find subsets S_1, \dots, S_q of $\{1, \dots, n - 1\}$ of size c such that for $j \in \{1, \dots, n - 1\}$, j occurs in d of the S_i 's.

Let $B_i = \sum_{j \in S_i} C^j$. Then B_1, \dots, B_q satisfy the hypotheses of the theorem and the result follows. \square

Let $n = 10$, $c = 3$, $d = 1$. Then by Corollary 6.9, there exists a directed strongly regular graph with parameters $(30, 9, 3, 2, 3)$, which is new.

The graphs constructed recently by Duval and Iourinski in [3] have adjacency matrices of the form given in Theorem 6.8 (with $d = 1$).

References

- [1] A. E. Brouwer, Parameters of directed strongly regular graphs, <http://homepages.cwi.nl/~aeb/math/dsrg/dsrg.html>
- [2] A. Duval. A directed graph version of strongly regular graphs. *JCT(A)* **47** (1988), 71-100.
- [3] Art M. Duval and Dmitri Iourinski. Semidirect product constructions of directed strongly regular graphs. *JCT(A)* **104** (2003), 157-167.
- [4] F. Fiedler, M. Klin, and Ch. Pech. Directed strongly regular graphs as elements of coherent algebras. In: *General Algebra and Discrete Mathematics*, Klaus Denecke and Hans-Jurgen Vogel (eds.); Shaker Verlag, Aachen, 1999, 69–87.
- [5] C. D. Godsil. *Algebraic Combinatorics*, Chapman and Hall, 1993.
- [6] S. A. Hobart and T. Justin Shaw. A note on a family of directed strongly regular graphs. *Europ. J. Combinatorics* **20** (1999), 819-820.

- [7] Leif K. Jørgensen. Directed strongly regular graphs with $\mu = \lambda$. *Discrete Math* **231** (2001), 289-293.
- [8] Leif K. Jørgensen. Non-existence of strongly regular graphs. *Discrete Math* **264** (2003), 111-126.
- [9] M. Klin, A. Munemasa, M. Muzychuk, and P.-H. Zieschang. Directed strongly regular graphs obtained from coherent algebras. *Linear Algebra Appl.* **377** (2004), 83–109.