

# Near-Infrared Laser Absorption of Poly(vinyl chloride) at Elevated Temperatures

James D. Van de Ven, Arthur G. Erdman

Mechanical Engineering Department, University of Minnesota, Minneapolis, Minnesota 55305

**Modeling laser transmission welding of thermoplastics requires knowledge of the optical properties of the materials being joined. The optical properties are highly dependent on their unique combinations of base polymer, pigments, and fillers. Because of the complex phase transition that occurs when heating thermoplastics, the optical properties are not a constant, but a function of temperature. During laser transmission welding large changes in the material temperature affect the light absorption, thus changing the characteristics of heating owing to the laser radiation. This paper discusses an experiment measuring diode laser transmission through clear poly(vinyl chloride) samples while increasing the material temperature in an oven. It was found that the absorption coefficient follows repeated peaks and valleys between the glass transition temperature and the melting point. Above the melting point the absorption coefficient increases to a plateau before a further increase that is marked by thermal decomposition. In addition, the decomposition temperature was found to be dependent on the rate of heating. J. VINYL ADDIT. TECHNOL., 12:166–173, 2006. © 2006 Society of Plastics Engineers**

## BACKGROUND

Most polymers in their natural, unpigmented state are highly transmissive of light in the near-infrared range, thus allowing laser transmission welding (LTW) with diode lasers. A complication arises, however, owing to most engineering plastics containing a variety of fillers and pigments that not only change the physical properties but also the optical properties. For this reason, testing the optical properties at a specific wavelength for all materials involved in LTW is required for accurate modeling.

There are numerous methods to test the optical properties of polymers, yet the field has not adopted a universally standard method. Early work measuring the transmission of a variety of pigmented ABS samples made use

of a quartz-halogen filament with a maximum output at 890 nm for the light source and a thermocouple for the measurement sensor [1]. Since that time, numerous other methods have been used to measure light transmission, most notably spectrometry and custom designed systems using low-powered laser sources and various methods of light detection [2, 3]. Within the near-infrared region natural polymers have nearly no absorption [2, 4]. Kagan and coworkers contributed a sizeable compilation of optical properties of nylon-based plastics containing various pigments and fillers [5, 6]. While optical property knowledge at ambient temperatures is an excellent baseline, a thorough model of the LTW also requires information about the optical properties at elevated temperatures.

As a thermoplastic is heated from ambient temperature through the glass transition temperature and into the melt region, changes in the crystalline structure occur. With these changes in crystalline structure, changes in optical properties also occur. A review of the literature yields that little work has been done analyzing the relationship between light absorption and temperature in thermoplastics.

In works modeling LTW, the absorption coefficient is generally assumed to be a constant throughout the entire process [2, 7]. Work by Becker proposed that the absorption coefficient is a function of temperature, following a curve similar to the material density. By using this model, the absorption coefficient decreases with increasing temperature. The curve of this relationship takes a large downward step as the material enters the melt phase. The reasoning behind this proposed relationship is that as the material expands, larger spaces will form between the atoms, thus allowing more light to pass through. Becker obtained the elevated temperature absorption values through an iterative approach of modifying the absorption coefficient in the model and comparing the output to the experimental data [8].

A second approach creating an absorption coefficient versus temperature relationship was performed by Korte. This work states that the absorption coefficient increased as a thermoplastic entered the melt temperature range [8, 9]. This is also the case for metals, where the absorption constant increases by approximately a factor of 3 at the

Correspondence to: James D. Van de Ven; e-mail: vandeven@me.umn.edu

DOI 10.1002/vnl.20085

Published online in Wiley InterScience (www.interscience.wiley.com).

© 2006 Society of Plastics Engineers

melting temperature [10]. Neither Korte's nor Becker's work defining an absorption coefficient versus temperature relationship utilizes optical testing. The work presented in this paper uses optical testing at elevated temperatures to create a relationship between the absorption coefficient and temperature.

## EXPERIMENTAL SETUP

The experimental device used to measure the optical properties of Poly(vinyl chloride) (PVC) at elevated temperatures is a custom designed black box with an oven. The black box uses a 4-mW diode laser module operating at a wavelength of 808 nm as a light source. Light from the diode laser is passed through a thermoplastic sample mounted in the oven and to a photodiode. By using an amplifying circuit to convert the current passing through the photodiode to a voltage signal that correlates to a power reading, the light transmission can be calculated by comparing the power with and without the sample. This entire system, illustrated in Fig. 1, is mounted inside a fully sealing wooden box that is painted flat black on the inside to reduce any light reflection.

The experiment involves careful measurement of the light energy reaching the photodiode, thus requiring a very low noise amplification circuit. The main trade-off for low noise circuit, which uses an OPA228 op-amp and a 100-mm<sup>2</sup> active area silicone photodiode, is slower circuit response. However, this is not a problem for this application. The spectral response of this photovoltaic

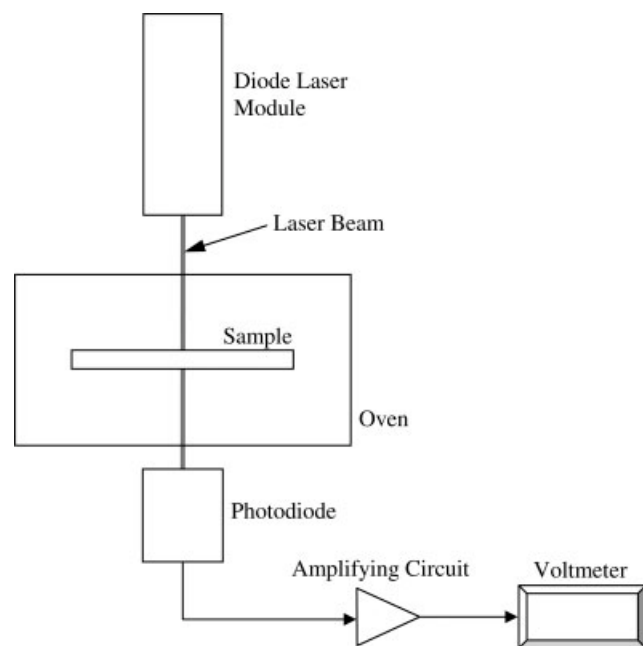

FIG. 1. Depicted is a diagram of the basic components of the black box. Light from the diode laser is passed through a sample and an aperture into a photodiode where a current is generated. The current passing through the photodiode is amplified and converted by the amplifying circuit to a voltage, which is displayed by the voltmeter.

photodiode peaks near 808 nm, thereby minimizing the influence of other light sources. The op-amp circuit has the benefit of allowing varying signal amplification through changing the value of the feedback resistor. To minimize any external noise, batteries power the photodiode amplification circuit and laser diode module. By using this device, light energy can be measured at values between 0.1  $\mu$ W and 5 mW.

The components in the black box need to be carefully aligned. The backbone of the fixturing is a  $\frac{3}{4}$ " square tube that is connected to the two farthest walls of the inside of the box. Mounted on the top of this tube are three stands. One holds the diode laser, a second supports the oven, and the third secures the photodiode. These stands are mounted in a manner allowing them to traverse the length of the tube as well as allowing a repeatable means of clamping and alignment.

The oven is designed to support the sample while allowing the laser beam to pass through the oven, thus keeping the electronics outside the oven. The goal of this system is to monitor the light transmission through a sample while simultaneously increasing the temperature into the melt range. Ideally, the photodiode would be mounted closer to the sample. However, the electrical noise increases with temperature, and the photodiode cannot operate above 125°C.

The cylindrical oven is 108 mm long and has an inside diameter of 76 mm. Access to the oven is achieved by pivoting the front panel, which is secured with a hinge parallel to the major axis of the cylinder. Mounted on each end of the oven are high-temperature pure quartz glass discs, which retain heat while allowing optical clarity owing to the very high optical transmission of quartz. The circumference of the oven is insulated with 25-mm thick fiberglass insulation.

A stand at the center of the oven provides a repeatable location for placing samples. Because the optical properties of interest extend into the melt region, a method of fixturing a melted sample is required. To meet this need, the black box is orientated vertically such that the laser beam is directed vertically downwards and the sample is fixtured horizontally. A piece of quartz glass is placed behind the sample to provide support of the melted polymer.

The oven is heated with two 400-mm-long 250-W heating elements, one at either end, which are formed into coils. The temperature of the oven is controlled with a commercially available fuzzy logic controller that uses a Type J thermocouple as a feedback sensor. This device allows control of the temperature ramp rate and the desired hold temperature. At maximum power, the oven is capable of heating from 20°C to 260°C in less than 4 min. The oven was tested to 370°C and exhibited stable operation with the ability to maintain a desired temperature  $\pm 1^\circ\text{C}$  throughout the entire operating range. A photograph of the open oven and optical components mounted in the black box can be found in Fig. 2.

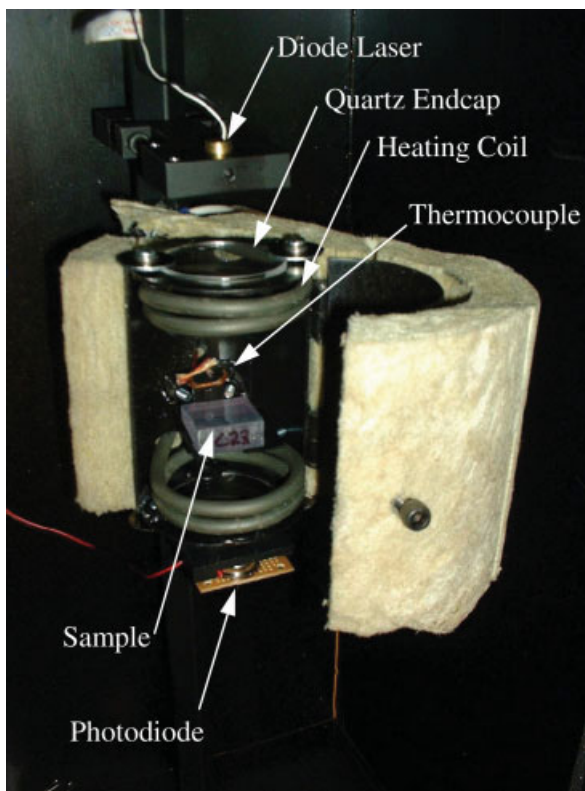

FIG. 2. This photograph shows the custom designed oven mounted in the black box. The two coils at the ends of the oven are the heating elements, and a thermocouple in the center of the oven acts as the temperature feedback sensor for the controller. The oven uses fiberglass insulation around the circumference and quartz glass endcaps. The sample is supported horizontally on a quartz glass plate to minimize material flow when reaching temperatures in the melting phase. [Color figure can be viewed in the online issue, which is available at [www.interscience.wiley.com](http://www.interscience.wiley.com).]

In addition to the thermocouple used for monitoring the air temperature in the oven, a second thermocouple is potted in the sample. This second thermocouple monitors the temperature of the thermoplastic sample by being placed in a 1.6-mm-diameter hole drilled in the side of each sample. This is an important feature of the experiment, as the air temperature and the sample temperature are often 10–20°C different, especially with higher temperature ramp rates, owing to the low thermal conductivity of plastics.

Because of the rapid temperature ramp rates and the need to record temperature and light transmission simultaneously, an automated method of acquiring data is necessary. A data acquisition system that interfaces with the USB port of a computer was purchased from National Instruments. This system includes two separate cards, one for –10 to +10 volt channels and the other for thermocouple channels. The photodiode amplification circuit is connected directly to the  $\pm 10$  V card, while the Type J thermocouple, potted in the sample, is connected to the second data acquisition card. By using a program created in Labview, these two signals were sampled, plotted, and written to file at a frequency of 4 Hz. It should be noted

that when heating the oven up to temperature with no sample present, the laser energy measured by the photodiode remained constant.

## EXPERIMENTAL PROCEDURE

The experiment is designed to establish a relationship between the absorption coefficient of clear rigid PVC and temperature. The experiment consisted of placing samples in the oven and monitoring the light transmission while increasing the temperature at various ramp rates. The purpose of varying the ramp rates was to determine how the time at elevated temperature affects the light transmission.

Square samples with side length of 25 mm were prepared from 3-mm-thick clear rigid PVC sheet purchased from K-mac Plastics. In the side of each of these samples a 1.6-mm-diameter hole was drilled approximately 4.8 mm deep, as can be seen in Fig. 3. The purpose of these holes is to pot the Type J thermocouple that is used to monitor the internal temperature of the sample as closely as possible. The sample thickness was chosen as a balance between being as thin as possible to allow rapid and even heating and being thick enough to allow drilling the hole for the thermocouple.

To explore the influence of time in addition to temperature on the light transmission, different rates of heating were utilized. Experiments were run at temperature ramp rates between 30°C/min and 60°C/min. Samples were heated from ambient temperature, through the glass transition temperature, into the melting phase, and to decomposition. Decomposition was characterized by a decrease in light transmission below 10%. In the decomposed condition, the samples were black and bubbling.

By using the data acquisition system, the temperature and light transmission were sampled at a frequency of 4 Hz. A small amount of noise was present within the voltage data from the photodiode amplification circuit. To

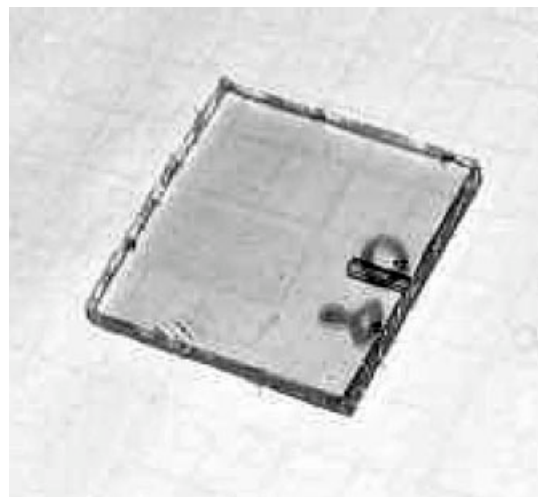

FIG. 3. This photo shows one of the prepared samples. On the right side of the sample can be seen the 1.6-mm diameter hole drilled for potting the thermocouple.

## Light Transmission vs. Temperature 30 deg C / minute

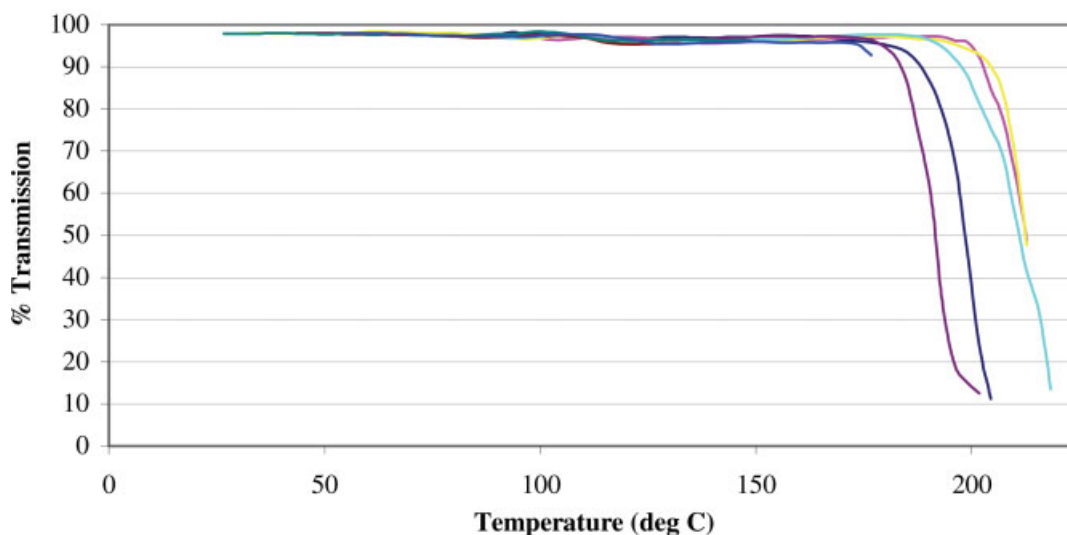

FIG. 4. Depicted is a graph of the light transmission through the samples as they are heated at a slow ramp rate of approximately 30°C/min. Note the drastic decrease in transmission near 200°C. [Color figure can be viewed in the online issue, which is available at [www.interscience.wiley.com](http://www.interscience.wiley.com).]

smooth this information, the light transmission data were averaged across 2.8°C increments.

The presence of the oven allowed light transmission through the sample to be measured, yet prohibited the measurement of light reflection. Previous work by the authors quantified the reflection from clear PVC samples of various thicknesses at ambient temperatures by interpolating to a zero thickness condition. This work found the average light reflection of clear smooth PVC to be 9% of the laser power [11]. By using the reflection fraction and the laser power, the light energy entering the sample can be calculated:

$$I_O = I_{\text{Laser}}(1 - R) \text{ (W/m}^2\text{)} \quad (1)$$

where  $I_O$  is the optical intensity entering the material,  $I_{\text{Laser}}$  is the laser intensity, and  $R$  is the reflection fraction. Light transmission through a solid follows an exponential decay with increasing material thickness. This relationship is defined by Beer's Law:

$$I(z) = I_O e^{-\alpha z} \text{ (W/m}^2\text{)} \quad (2)$$

where  $I(z)$  is the optical intensity as a function of material depth,  $\alpha$  is the absorption coefficient, and  $z$  is the depth into the material [12]. By using these two equations and the light energy reaching the photodiode with and without a sample in place, the absorption coefficient can be calculated. This approach assumes that the light reflection does not vary with temperature. Another term also discussed is the light transmission, which is defined as:

$$\%T = \frac{I(z)}{I_O} \times 100 = 100 \times e^{-\alpha z} \quad (3)$$

where  $z$ , the depth into the material, is set to the material thickness.

## RESULTS

The results of the experiment are quite dependent on the rate of heating. Two notable findings result from the experiments run at slow ramp rates. First, the light transmission decreases dramatically when reaching 190–205°C, as can be seen in Fig. 4. This decrease in light transmission corresponds to an increase in the absorption coefficient, a result which is contrary to the previous work in the field [8]. Second, the apparently constant light transmission region before the drastic decrease is characterized by fluctuations beginning near the glass transition temperature, 77–80°C [13, 14]. These fluctuations were not random, but repeated by all the samples with only minor offsets in temperature as seen in Fig. 5.

The more rapid temperature ramp rates created interesting results. At temperatures below 180°C, the plots of the faster temperature ramp-rate experiments quite closely matched the behavior for the slower ramp-rates presented above. These plots are characterized by the repeated peaks and valleys between the glass transition temperature and the melting phase. However, the rapid decrease in light transmission previously found near 200°C no longer extended to below 10% transmission, but recovered to reach a subsequent peak before decomposition at a higher temperature. Figure 6 shows a plot of the light transmission as a function of temperature for experiments run at the maximum ramp rate of approximately 60°C/min.

## DISCUSSION

The heating phase of LTW is quite rapid, and while the described oven will not be able to match this rate of

### Light Transmission vs. Temperature 30 deg C / minute

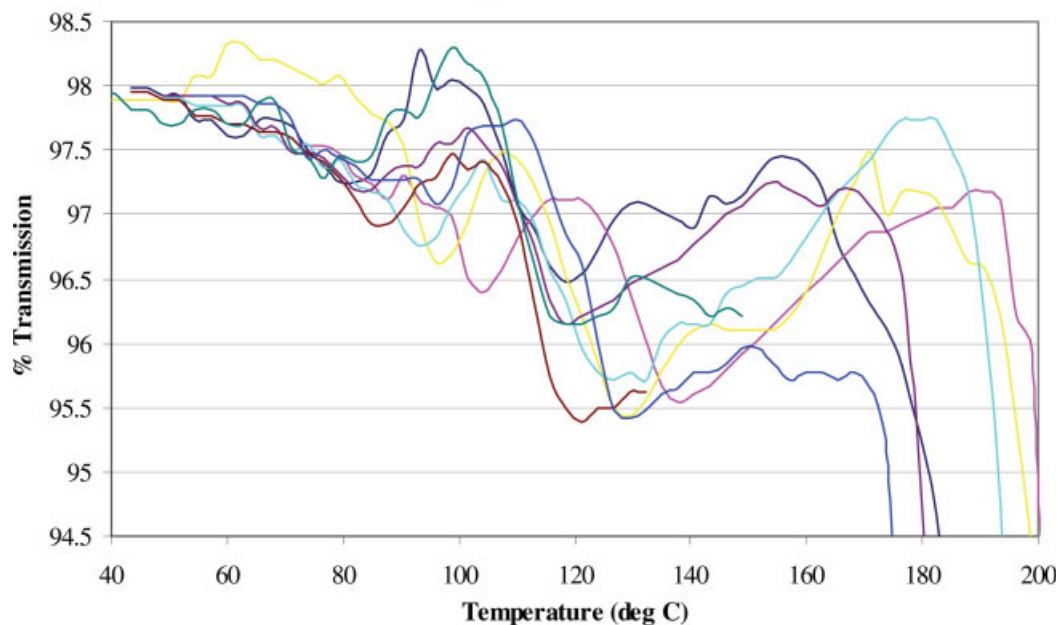

FIG. 5. This graph is a zoomed view of the apparently constant region of Fig. 6. Note that the fluctuations in light transmission are repeated for each sample and begin near the glass transition temperature. [Color figure can be viewed in the online issue, which is available at [www.interscience.wiley.com](http://www.interscience.wiley.com).]

heating, much understanding is gained of the relationship between temperature and light transmission. Two generalizations can be made from the acquired data that are inde-

pendent of the temperature ramp rate, within the region tested. First, the light transmission reaches repeated peaks and valleys between the glass transition temperature and

### Light Transmission vs. Temperature 60 deg C / minute

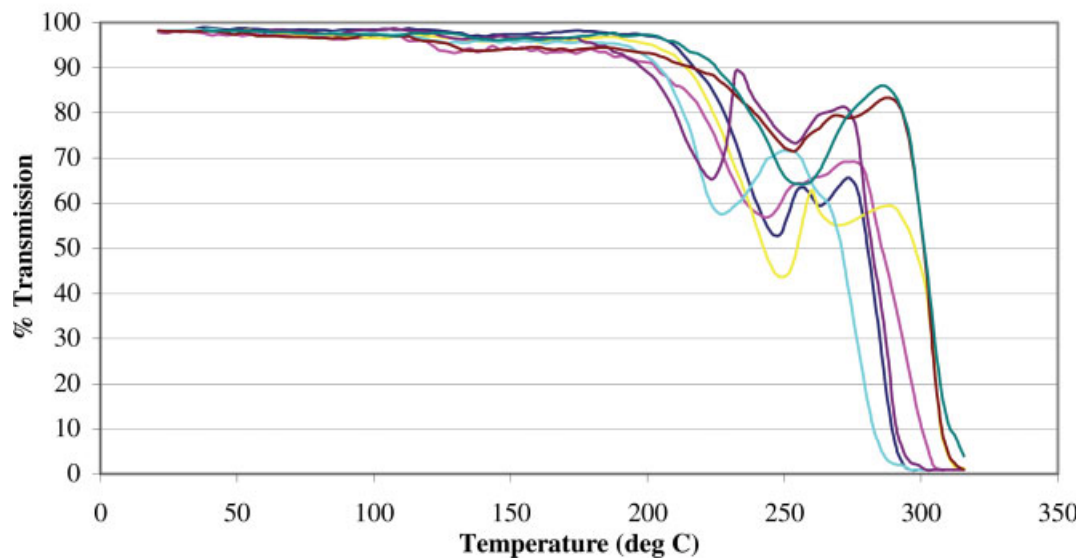

FIG. 6. This graph shows the light transmission as a function of temperature when heating at a higher ramp rate of approximately 60°C/min. Note that near 200°C the light transmission drops and then reaches a second peak before decomposition. [Color figure can be viewed in the online issue, which is available at [www.interscience.wiley.com](http://www.interscience.wiley.com).]

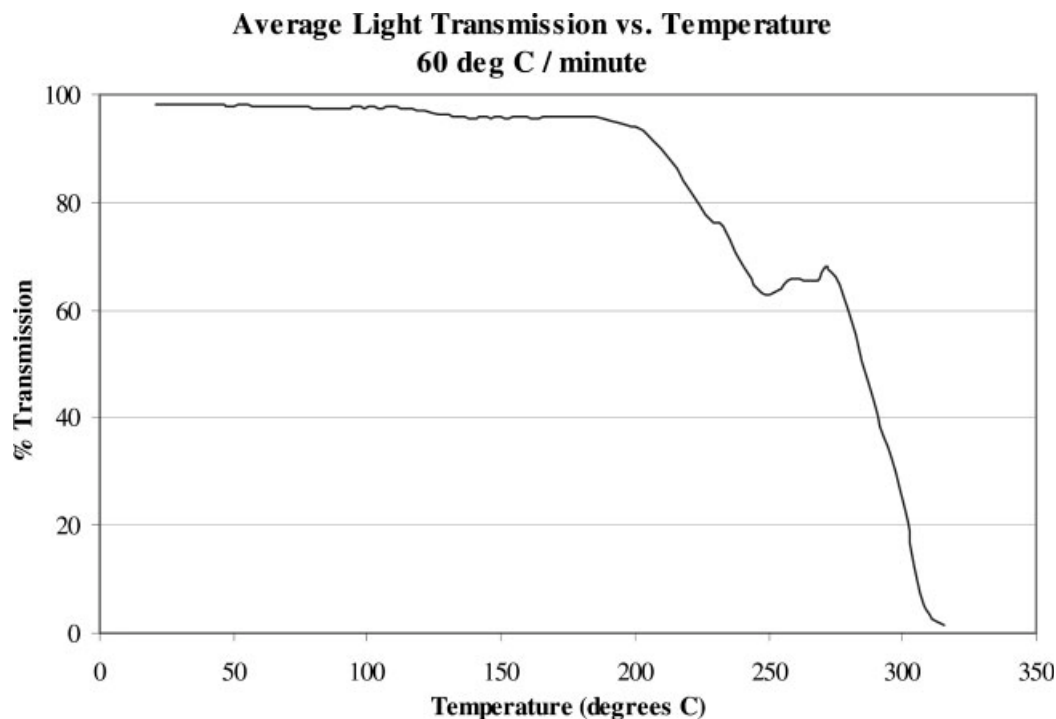

FIG. 7. This graph shows the averaged light transmission as a function of temperature for the 60°C/min temperature ramp rate.

the melting phase. Second, there is a decrease in the light transmission through all samples near 200°C.

The goal of the oven testing is to provide absorption vs. temperature data to use in a heat-transfer model of the heating phase. Logically, the data from the fastest temperature ramp-rate, 60°C/min, should be used for this model, as the rapid heating more closely approximates the conditions of LTW. To package this information, the data depicted in Fig. 6 were averaged at 2.8°C temperature steps to create a look-up table. A plot of these averaged values can be found in Fig. 7.

As seen in these experiments, the decomposition of PVC is strongly dependent on the time of exposure to elevated temperatures. During decomposition, the dechlorination of PVC forms hydrogen chloride, which accelerates the decomposition process; for this reason, PVC thermolysis is considered to be autocatalytic [15]. This characteristic allows extreme temperatures, approaching 500°C [16], to be reached for very short time periods during LTW.

Characterizing PVC properties at the maximum temperatures reached during LTW is difficult due to its autocatalytic degradation. A question needs to be posed: What would the light transmission curve look like if the heating rate could be increased to match the conditions present in LTW? Answering this question is beyond the capability of the custom oven in the black box.

In an effort to create the best model possible for LTW modeling, some speculation will be made. The rapid decrease in light transmission in the above experiments is characterized by charring of the material. It is logical to

expect that if the sample were not decomposing at those temperatures, the light transmission would not drastically decrease. A light transmission model for rapid heating, such as is present in LTW, should follow the general form of Fig. 7 to approximately 270°C, where decomposition is not yet affecting the results. Above this temperature, the author postulates that the light transmission remains relatively constant with increasing temperature if decomposition does not occur.

By using the postulation about light transmission during rapid heating of PVC, a new model can be constructed. This model, as seen in Fig. 8, uses the average of the experimental data from the 60°C/min temperature ramp rate specimens up to 270°C and continues at a plateau at this temperature. The termination of this plateau should be dictated by material decomposition. In modeling LTW this work assumes that the heating is rapid enough to prevent significant decomposition throughout the welding temperatures. By using Beer's Law [12], the previously predicted light reflection, and the sample thickness of 3 mm, the absorption coefficient can be calculated from the transmission data. A plot of the predicted absorption coefficient as a function of temperature at rapid heating rates for clear PVC can be found in Fig. 9; this information can be used in the form of a look-up table in the LTW model.

The creation of a relationship between the absorption coefficient and temperature contains many possible sources of error. First, light reflection could not be measured in this experiment. Instead, a baseline reflection value was

### Light Transmission vs. Temperature Model Rapid Rate of Heating

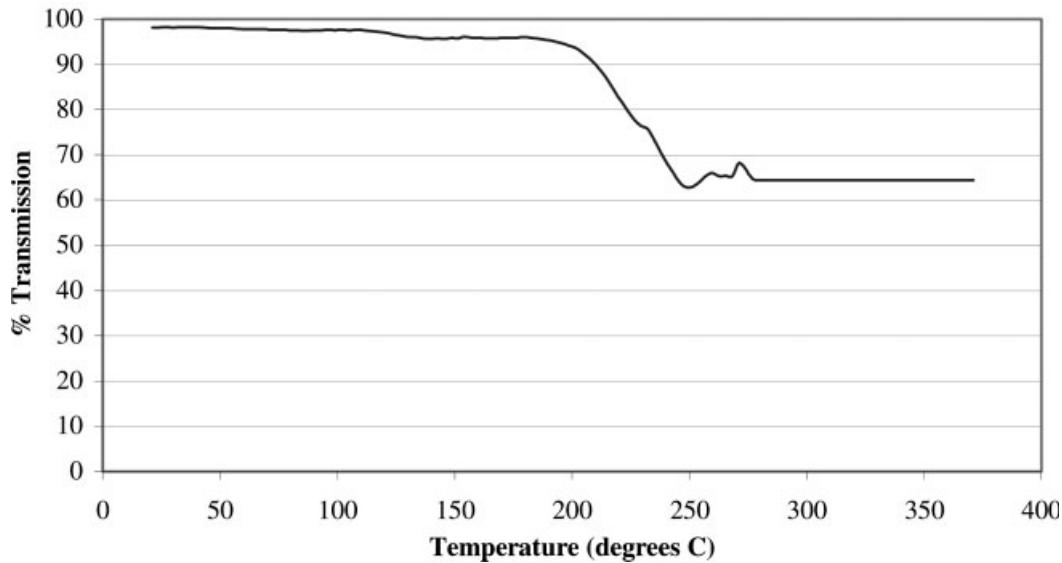

FIG. 8. This is a graph of the predicted light transmission of clear PVC when rapidly heated to elevated temperatures. This plot is created by using the experimental data to the point of decomposition, then maintaining the transmission value of the last peak.

used based on previous work interpolating transmission data to a zero thickness condition by using samples of varying thickness. It was assumed that the light reflection does not change as a function of temperature. Second, the temperature measurement of the samples in the oven needs to be questioned. A thermocouple was placed inside a drilled hole in each sample; yet as the sample melted, the

exact location of the thermocouple junction was unknown. The 3-mm thick PVC samples most likely did not have a constant temperature throughout the entire specimen. The measured temperature in the middle of the specimen was most likely cooler than that of the outer surfaces. Finally, the thermocouple could be giving a false reading owing to absorbing radiation from the heating coils.

### Absorption Coefficient vs. Temperature Model Rapid Rate of Heating

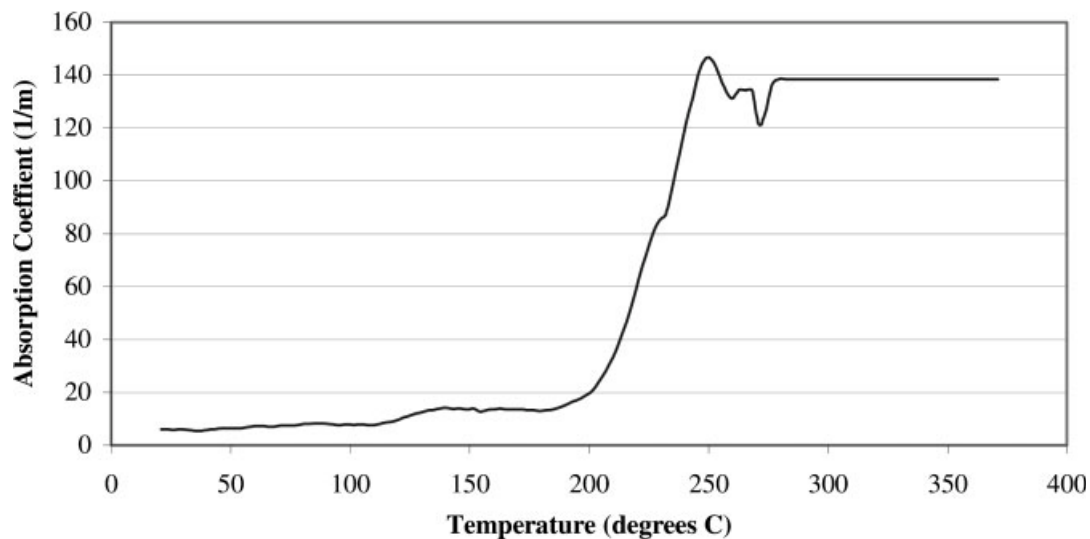

FIG. 9. This is a plot of the postulated absorption coefficient as a function of temperature during rapid heating. This coefficient is formed from experimental data before the point of decomposition and a constant value beyond this temperature. This information is stored in a look-up table to be used in a mathematical model of the LTW process.

Beyond the mechanical sources of error, a major speculation is made to predict the absorption coefficient during rapid heating at temperatures above those producing decomposition in this experiment. Without further information, this speculation appears to be a logical choice, yet is completely untested. While a complete understanding is not existent, using this model is accurate into the melting phase at 270°C and is a better solution than using a constant absorption coefficient as described in some previous works.

## CONCLUSION

During all previous modeling of LTW in thermoplastics, the influence of temperature on the absorption coefficient was not well understood. To further this understanding, a method was devised to monitor the light transmission through a thermoplastic sample while heating it from ambient temperature to decomposition. A small cylindrical oven mounted inside a black box was used to heat the plastic samples. With the aid of a data acquisition system, temperature and light transmission data were collected for numerous samples.

Owing to the oven being enclosed around the circumference, the light reflected from the samples could not be measured. Instead, this experiment leveraged previous work by the authors calculating light reflection from clear PVC samples of various thicknesses. The assumption was made that the reflection remained constant with changes in temperature. This assumption may not be entirely valid because of changes in the material surface with increasing temperature or other mechanisms. Without the ability to measure the reflection directly during this experiment, a constant reflection was assumed. Using this information allowed a relationship to be formed between the absorption coefficient and the temperature of clear PVC.

The process of LTW uses a very high energy density to heat the weld zone locally; this energy causes very rapid heating of the polymer. In contrast, heating a polymer in an oven results in a slower and more uniform heating. Because of the autocatalytic nature of PVC thermolysis, thermal decomposition is highly dependent on the time of exposure to the elevated temperatures. The result of this situation is that polymer decomposition occurs at lower temperatures when the polymer is heated in an oven than when it is exposed to the instantaneous temperatures of laser welding. Creating a relationship of the absorption coefficient for an LTW model is challenging for the rapid heating rates found in welding.

In response to the issue of modeling the absorption coefficient at temperatures beyond the capabilities of this experiment, a prediction was made. Within all the experiments described in this paper, the light transmission follows repeated peaks and valleys between the glass transition temperature and the melting point. In addition, there exists a general decrease in light transmission near 200°C. In the samples heated at a more rapid rate, this decline is followed by a second peak before declining to decomposition. A prediction is made that if the material did not

decompose at this point, the light transmission would remain relatively stable at higher temperatures. The main reason for this prediction of stable light transmission is that further phase change is not occurring in this melt region.

The finding that the absorption coefficient increases near 200°C is vitally important to modeling LTW. When using previous assumptions that the absorption coefficient of the “transparent” material remains constant, or decreases [8], a model predicts that the “absorbent” material absorbs all of the laser energy. Upon using the new information regarding the increase in the absorption coefficient with increasing temperature, the absorption in the weld zone changes. When the “transparent” part is heated through conduction from the “absorbing” part, both the “transparent” and the “absorptive” parts will be absorbing laser energy, thus changing the energy distribution in the joint.

## ACKNOWLEDGMENTS

The authors thank Andersen Corporation, Bayport, MN, for generously sponsoring this work.

## REFERENCES

1. R.A. Grimm, *Adv. Mater. Process.*, **147**, 3 (1995).
2. F.G. Bachmann and U.A. Russek, *Proc. SPIE-Int. Soc. Opt. Eng.*, 4637 (2002).
3. K. Inada, R. Matsuda, C. Fujiwara, M. Nomura, T. Tamon, I. Nishihara, T. Takao, and T. Fujita, *Conservat. Recycl.*, **33** (2001).
4. S. Hartley and R.A. Sallavanti, *Proc. SPIE-Int. Soc. Opt. Eng.*, 4830 (2002).
5. V.A. Kagan, R.G. Bray, and W.P. Kuhn, *J. Reinforced Plast. Compos.*, **21**, 12 (2002).
6. V.A. Kagan and G.P. Pinho, *J. Reinforced Plast. Compos.*, **23**, 1 (2004).
7. U.A. Russek, A. Palmen, H. Staub, J. Pohler, C. Wenzlau, G. Otto, M. Poggel, A. Koeppel, and H. Kind, *Proc. SPIE-Int. Soc. Opt. Eng.*, 4977 (2003).
8. F. Becker, *Einsatz des Laserdurchstrahlschweißens*, Ph.D. Thesis, University of Paderborn (2003).
9. J. Korte, *Laserschweissen von Thermoplasten*, Ph.D. Thesis, University of Paderborn (1997).
10. W.W. Duley, *Heat Transfer and Modelling in Laser Welding*, Wiley, New York, 67 (1999).
11. J. Van de Ven, “Chapter 2: Optical Testing: Transmission and Diffusion,” Ph.D. Thesis, University of Minnesota (2006).
12. M. Fox, *Optical Properties of Solids*, Oxford University Press, Oxford (2001).
13. B.F. Abu-Sharkh, *Comput. Theor. Polym. Sci.*, **11**, 1 (2001).
14. I.C. McNeill, L. Memetea, and W.J. Cole, *Polym. Degrad. Stab.*, **49**, 181 (1995).
15. K. Patel, A. Velazquez, H.S. Calderon, and G.R. Brown, *J. Appl. Polym. Sci.*, **44(11)**, 179 (1992).
16. K. Sato, Y. Kurosaki, T. Saito, and I. Satoh, *Photon Process. Microelectron. Photon.*, 4637 (2002).