

COMPUTATIONAL DEVELOPMENT OF A GAS TO LIQUID HEAT EXCHANGER WITH A BREATHING OPERATION

Richard N. Jorgenson  
Worcester Polytechnic Institute  
Worcester, MA, USA

James D. Van de Ven  
Worcester Polytechnic Institute  
Worcester, MA, USA

ABSTRACT

Thermal conditioning of a gas during compression and expansion processes requires rapid transfer of heat. Proposed is a thin flexible membrane with a biologically-inspired, lung-like structure characterized by branching tubes, massive surface area, and low overall pressure drops. By forcing the working gas into contact with the large surface area of a thin membrane, rapid heat transfer may be achieved across the membrane and into a liquid bath. Inspiration and expiration of the gas is driven by volume changes in the liquid bath.

A computational approach is taken to the design of the lung-like structure. First, Non-dominated Sorting Genetic Algorithm II (NSGA-II) is run to optimize elemental geometries for minimum pressure drop and maximum heat transfer. In the initial case, 2D elements are passed through Gambit and Fluent to evaluate the fitness function. Here, we present the results of the elemental optimization. In the future, 3D elements will be analyzed and connected in an optimal way to generate a 3D lung-like structure.

INTRODUCTION

Context

There exists a need for technology enabling rapid heat transfer between a gas and a liquid. Gas compression processes and a conceptual Liquid Piston Stirling Engine are immediate applications. Proposed is a thin, flexible, membrane structure separating a gas from a liquid bath. The membrane presents massive surface area to the gas and liquid, facilitating rapid heat transfer. As the gas enters the membrane, the structure expands, heat is transferred across the membrane walls, and the gas is expelled as the structure collapses, as illustrated in Figure 1. The cycle is conceptually similar to a breathing operation.

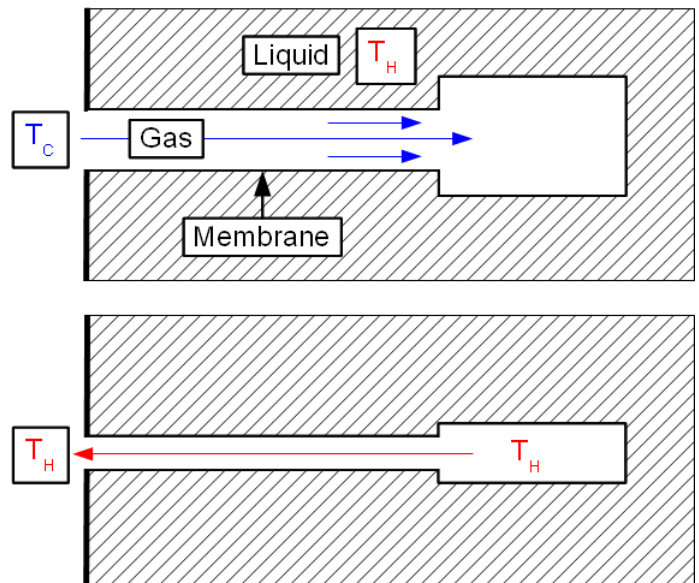

FIGURE 1: SCHEMATIC OF BREATHING OPERATION OF HEAT EXCHANGER MEMBRANE.

The membrane has a special structure to efficiently and effectively transfer air from the inlet to the terminal surface area. Lung-like structures already accomplish this task for gas diffusion operations, which also requires large surface area for rapid gas diffusion (approximately  $70 \text{ m}^2$  in humans [1]). The similarity between gas diffusion and heat transfer objectives motivates further study of branching structures as a breathing heat exchanger (BHEX) solution.

Previous Research

Bejan extensively explored branched structures in his work [2] which was an inspiration for the BHEX concept. He draws connections between optimal engineering design and

existing biological structures. The structure of lungs was explored.

Pulmonary structures and their fluid dynamics were reviewed by Pedley [1] before the benefit of computational fluid dynamics (CFD) software. He provides analytic approximations to velocity profiles in a symmetric bifurcation as well as describing the physiology of human and non-human lungs.

The structure of a human lung comprises about 20 levels of bifurcation from bronchial tube to alveoli, which introduces inspired air to an approximately 70 m<sup>2</sup> alveolar area. The bifurcations increase in total cross-sectional area from bronchial tube to alveoli. The ratio of branch to root diameter  $\alpha = d_1/d_0$  was measured to be approximately 0.78 [1]. This is close to the ratio arrived at by Murray's law for vascular junctions, where  $\alpha = 2^{-1/3} \cong 0.79$  [3].

Murray's law is derived by supposing that biological flow systems have evolved to require the least possible biological work to support. The total energy required by biological flow systems is the sum of pumping energy and metabolic energy required to support living tissue [3]. The ratio  $\alpha = 2^{-1/3}$  describes the optimal ratio of a root diameter in a symmetric bifurcation; a trade-off between low pressure drop and minimum metabolic tissue cross-section. Sherman showed that Murray's law is also valid for inanimate systems flow systems that also have a cost associated with tube cross-section or volume [21 Sherman, TF 1981]. The outcome of optimization in this work will be compared to the predictions of Murray's law.

Pedley describes an airway resistance, defined as the pressure drop across an element divided by the volumetric flow rate through the element [42 Pedley, T.J. 1977]. In this work, the airway resistance is termed flow resistance.

### Genetic Algorithm and CFD Software

The goal of this work is to engineer an optimal membrane structure beginning with an optimal elemental branch. The heat transfer (HT) and flow resistance (FR) across an elemental branch will be evaluated and the optimal geometry found for maximum HT, minimum FR.

A few tools are already available to help with this task. Commercial CFD packages allow for easy analysis of the heat transfer and pressure drop for complex geometries. Gambit was used as the geometry mesher and Fluent solved the flow problem. A method for varying the geometry of an elemental branch was required that will eventually converge to a set of optimal geometries.

Evolutionary or genetic algorithms are beginning to find applications in optimal design, especially in concert with CFD software [4]. Genetic algorithms are an attractive tool from an engineering perspective because they are relatively easy to code and can quickly produce useful results.

The elemental branch optimization problem is a multi-objective problem; the fitness of a branch is a two element vector of HT and FR. A multi-objective evolutionary algorithm called "Non-dominated Sorting Genetic Algorithm II" (NSGA-

II) [5] allows for the optimization of two or more objectives without introducing weighting factors and the complications they bring. Central to NSGA-II and multi-objective algorithms in general is the concept of a non-dominated solution. In the minimization context, a solution  $v$  dominates  $u$  if  $v p < u$ , where  $p <$  means "partially less than."

$$v p < u \text{ if } v_i \leq u_i \text{ for every } i \text{ and} \\ v_i < u_i \text{ for at least one } i, \\ i = 1, 2, \dots, \text{length}(v) \quad (1)$$

A solution vector that is not dominated by any other solution vector is termed "non-dominated."

The distinguishing feature of NSGA-II is sorting solution vectors into "ranks," where a rank 1 solution is non-dominated, a rank 2 solution is dominated one other solution, and the maximum rank solution does not dominate any other solutions. The set of rank 1 vectors left at the termination of the algorithm constitute a set of solutions that are no worse than any other solution.

## METHODS

### Problem Setup

The root branch of the HEX structure was optimized first, with the assumption that the outflow field could be passed on to the inflow of a second-level branch later.

The elemental branch was assumed to be rigid and two-dimensional. Future work will consider flexible walls and may consider three-dimensional branches.

A uniform inflow velocity at a constant temperature of 300 K was specified for the first elemental branch. The walls were considered isothermal at 500 K because the HEX structure would be immersed in a temperature-controlled liquid bath. The HEX volume was specified at 200 mL and the operating frequency at 10 Hz.

A schematic of an elemental branch is shown in Figure 2 with the parameter set  $\{\alpha, \beta, \gamma, d_0, n\}$  representing diameter ratio, length ratio, spacing angle, root diameter, and number of branches, respectively. The set of three vector  $\{\alpha, \beta, \gamma\}$  and two scalar  $\{d_0, n\}$  parameters allows for a symmetric element with multiple branches that can each have their own length and diameter ratios. The length of vectors  $\{\alpha, \beta, \gamma\}$  change depending on  $n$ , the number of branches. In this work, a maximum of eight branches are allowed.

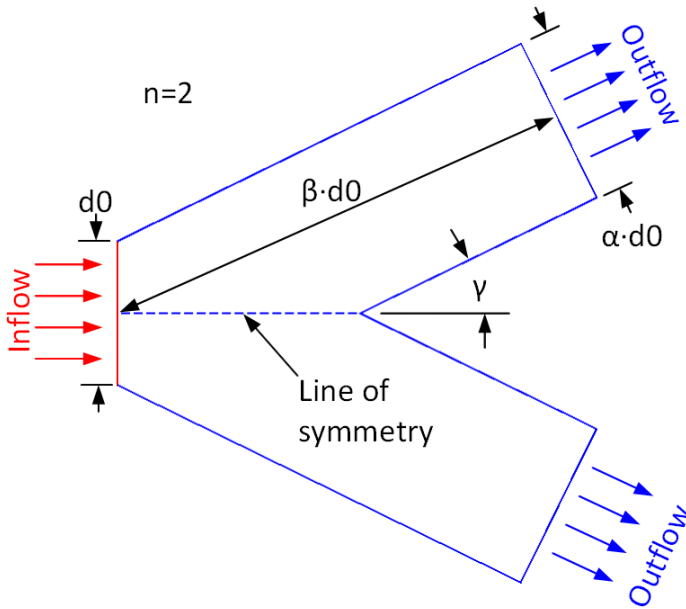

FIGURE 2: SCHEMATIC OF SYMMETRIC BRANCH AND THE PARAMETERS THAT SET ITS GEOMETRY.

### Solution Method

A population was initialized with random parameter sets for each individual. Parameters were then varied using NSGA-II and fitness was evaluated with Fluent.

A program was written that contains the NSGA-II algorithm as well as code to generate journal files for batch processing in Gambit/Fluent. The program can be run with any of the parameters  $\{\alpha, \beta, \gamma, d_0, n\}$  held constant to explore optimum geometries subject to specific constraints.

### Program Overview

The high-level program structure for optimizing the elemental branch geometry is shown in Figure 3. It consists of an initialization loop and an evolutionary loop, distinguished by meshFitEval and cfdFitEval, respectively.

The initialization loop rolls random parameter sets and, via meshFitEval, checks to see if there are enough good geometries to begin the evolutionary loop. Generally, it was observed that random parameter sets mostly result in highly deformed geometries that are un-meshable. A minimum of three meshable geometries are required to start the evolutionary loop. If a decent parameter set already exists (which could be the results of a previous evolution), that set can be loaded instead of initializing from random each time.

The evolutionary loop takes a parameter set and modifies it until convergence is detected, discussed further in the Program Specifics section. The NSGA-II algorithm drives the evolutionary loop, the components of which are highlighted in Figure 3. The tournament selection, crossover and mutation, and offspring steps are common to most genetic algorithms. Konak, et al provide an overview of several multi-objective genetic algorithms [6], including NSGA-II. Gosselin et al review the use of genetic algorithms in heat transfer problems

[4] and note that NSGA-II is the preferred algorithm for multi-objective optimization.

In the tournament selection (“Tourney” step in Figure 3),  $trnLvl$  randomly selected fitness vectors are compared to each other, where  $trnLvl \geq 2$ . The winner of each tournament will be a parent for the next generation. In all,  $N$  parents are selected, where  $N$  is the number of individuals in the population.

For example, suppose the vectors shown in Table 1 represent fitness values of three randomly selected parameters. In this case  $trnLvl = 3$ , and the winner of the tournament will become a parent for the next generation. First,  $gaFit(13)$  and  $gaFit(2)$  are compared to see if one is partially-less-than ( $p <$ ) the other (equation 1). Since neither is partially-less-than the other, they are considered equal and one is randomly selected as the winner. If  $gaFit(2)$  was selected, it would then be compared to  $gaFit(10)$  to see if one was partially-less-than the other. In this example,  $gaFit(2) p < gaFit(10)$  and  $gaFit(2)$  is the tournament winner.

TABLE 1: EXAMPLE OF TOURNAMENT SELECTION.

$gaFit(13)$ = $\begin{bmatrix} 0.3941 \\ -647.5 \end{bmatrix}$	$gaFit(2)$ = $\begin{bmatrix} 0.5280 \\ -652.1 \end{bmatrix}$	$gaFit(10)$ = $\begin{bmatrix} 0.7138 \\ -643.0 \end{bmatrix}$
---	--	---

The  $N$  winners are combined in the crossover and mutation (“SBX & Mutator”) step to produce  $N$  children. SBX stands for Simulated Binary Crossover [7], a technique for combining two parent real numbers and producing two child real numbers a certain distance away from the parents, where the distance and direction is determined by a probability distribution. The “Mutator” step shifts the child values slightly with some probability of occurrence (20% chance of mutation in this implementation) and using the same probability distribution as the SBX step.

In the “Create Children” step, the child parameter sets are copied to a new structure in preparation for evaluation of their fitness via cfdFitEval.

Rank and distance values are assigned after the structure comes back from cfdFitEval. Rank is determined by a fast non-dominated sorting (FNS) algorithm described by Deb [5]. Distance values are assigned to fitness vectors of the same rank as a way to determine how “crowded” a particular area of the solution space is. Fitness values of the same rank are differentiated by preferring solutions in a less crowded area of the solution space [5].

The parent and child populations are then combined and rank is re-assigned for the combined populations using the FNS algorithm. The  $N$  best (i.e. lowest rank) solutions are selected and returned as the final child population. Because the best solutions from the combined parent and child populations are selected after each iteration, the best solutions over all generations propagate. The propagation of the best all-time

solutions is termed “elitism” and NSGA-II is an “elitist” algorithm.

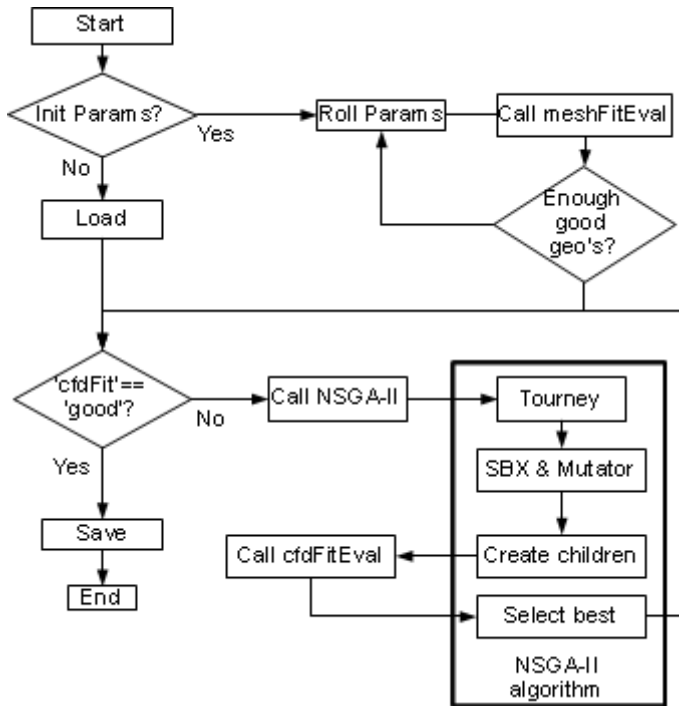

**FIGURE 3: PROGRAM STRUCTURE FOR OPTIMIZING ELEMENTAL BRANCH GEOMETRY.**

The subroutine cfdFitEval generates journal files for Fluent and Gambit for batch processing of the vertex data generated from each parameter set. The higher-level function of cfdFitEval is shown in Figure 4. After Gambit meshes parameter sets, the meshable indices are detected and the Fluent journal file is generated. Fluent then reads each journal file and runs the CFD simulation until convergence (if any), writing HT/FR data to files for each parameter set. Fluent simulation parameters are discussed further in the Program Specifics section.



**FIGURE 4: GENERATION OF HEAT TRANSFER AND PRESSURE DROP DATA FROM CFDITEVAL.**

### Program Specifics

Convergence is detected by tracking the percent change in Rank 1 fitness values over a 3-generation window. Once the maximum change for either HT or FR is less than 5% across 3 generations, the algorithm has converged on a solution.

The Fluent analysis was run in the 2D, single precision solver using a 1<sup>st</sup> order upwind, steady state scheme. The energy equations were included in the solution to obtain heat

transfer values. The fluid was helium, copied from the Fluent materials database. The inlet boundary was uniform mass-flow inflow at 300 K. The walls were isothermal at 500K. Residuals were monitored to determine convergence (if any). A transcript file was written for each individual so that the evolutionary program could detect CFD convergence. Heat transfer, total pressure, and volumetric flow rate data were then written to files.

A summary of pertinent genetic algorithm parameters is shown in Table 2. A tournament level of 2 means fitness vectors were compared in pairs to choose parents for the next generation. The distribution index controls the flatness of the probability distribution for crossover and mutation. A lower integer value results in a flat and wide distribution [7]. Mutation probability controls the chance that a child parameter set will mutate. The max mutation perturbation is the maximum allowable change in parameter values during mutation, as a percentage of the allowable parameter range (upper bounds minus lower bounds). A summary of Fluent parameters is shown in Table 3.

**TABLE 2: GENETIC ALGORITHM PARAMETERS.**

Tournament Level	2
Distribution index	3
Mutation Probability	10%
Max mutation perturbation	60%

**TABLE 3: CFD SOLVER PARAMETERS.**

Solver	2D, single-precision, pressure-based, laminar, steady-state
Equations	Flow, energy
P-V coupling	SIMPLE
Discretization Scheme	<ul style="list-style-type: none"> <li>Momentum and energy: First-order upwind</li> <li>Pressure: Standard</li> </ul>
Boundary Conditions	<ul style="list-style-type: none"> <li>Isothermal wall, 500K</li> <li>Isothermal mass-flow inlet, 300K, 7.144E-4 kg/s</li> <li>Helium gas</li> </ul>

### RESULTS

The genetic algorithm was run for 30 generations with a population size of 20. The parameters and fitness of the rank 1 solution are shown in Table 4. In the fitness vector, the first element is flow resistance in units of  $\frac{Pa}{m^3/s}$  and the second element is the negative heat transfer in units of  $W$ . The root diameter is in units of  $m$ .

The branch length ratio  $\beta$  has settled at the upper bound of 5 diameters. The optimal branch is a bifurcation.

**TABLE 4: RANK 1 SOLUTION PARAMETERS AND FITNESS AFTER 30 GENERATIONS.**

$\alpha = 1.3438$
$\beta = 5$
$\gamma = 2.5072 = 0.7981\pi$
$d0 = 6.6743 \times 10^{-2} \text{ m}$
$n = 2$
$gaFit = \begin{bmatrix} 0.3941 \frac{Pa}{m^3/s} \\ -647.5 W \end{bmatrix}$

The pressure, temperature, and velocity contours for the rank 1 solution are shown in Figure 5 through Figure 7. Because the elemental branches are symmetric, only one half of the element was solved. The contours were mirrored across the line of symmetry for presentation purposes. There is a high-pressure dead zone directly in front of the inlet.

Figure 8 depicts the fitness of rank 1 solutions across 30 generations. Lower negative heat transfer and flow resistance values are better. The 30<sup>th</sup> generation is indicated by the point at the lower left.

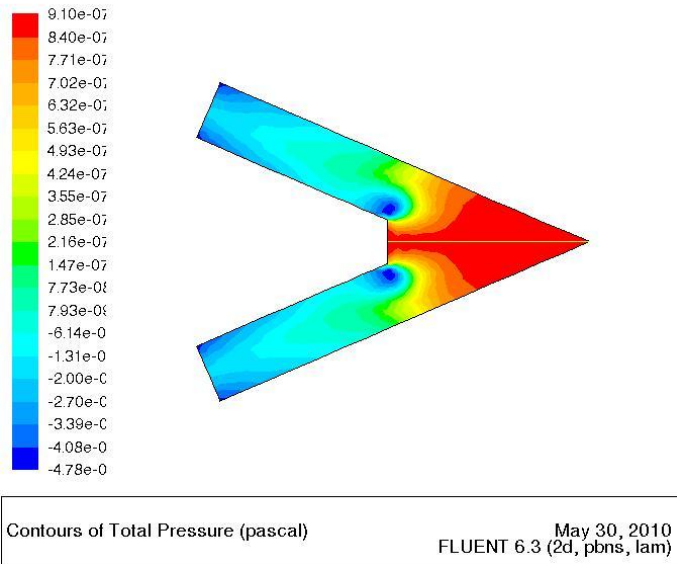

**FIGURE 5: TOTAL PRESSURE CONTOURS OF A RANK 1 SOLUTION AFTER 30 GENERATIONS**

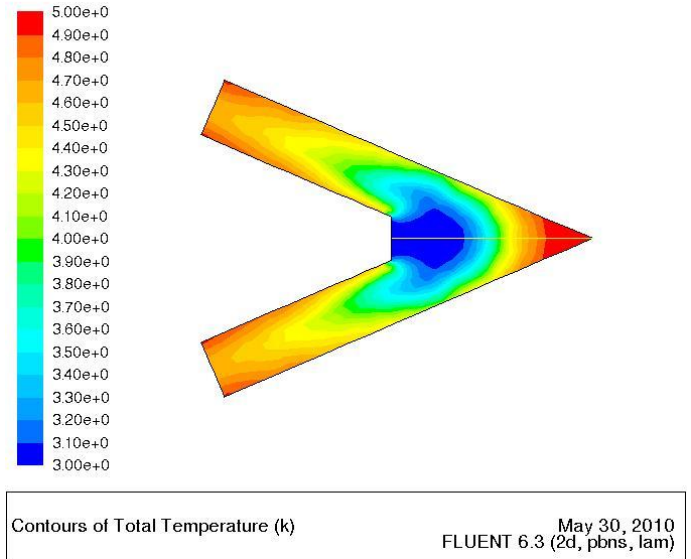

**FIGURE 6: TOTAL TEMPERATURE CONTOURS OF A RANK 1 SOLUTION AFTER 30 GENERATIONS.**

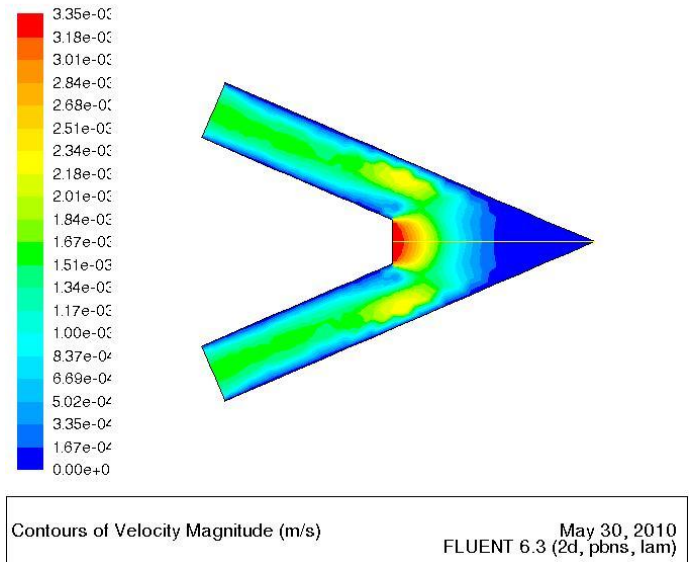

**FIGURE 7: VELOCITY MAGNITUDE CONTOURS OF A RANK 1 SOLUTION AFTER 30 GENERATIONS.**

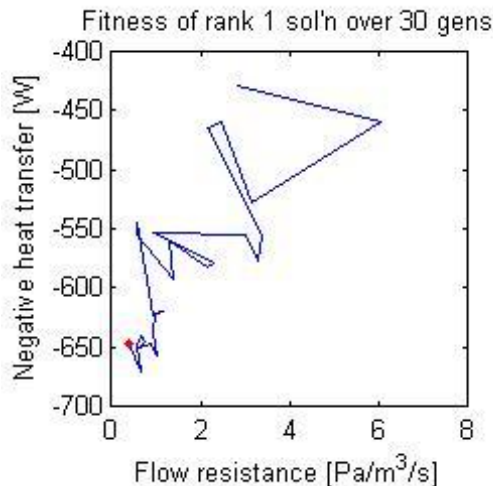

**FIGURE 8: FITNESS VALUES OF RANK 1 SOLUTIONS OVER 30 GENERATIONS.**

## CONCLUSIONS

The results are interesting, but it would be difficult to connect such awkwardly-shaped elements in an optimal way. It is not immediately clear how to accomplish this, based on the original assumption that optimal elements could be assembled into an optimal structure. However, the evolutionary algorithm is promising as a development tool. It provides a means of solving a variety of heat transfer design problems [4] that would be otherwise difficult.

The algorithm also forces the designer to very carefully consider the constraints and the setup of the optimization problem. A unique geometry might be the best solution to the wrong problem, that is, a problem that is different from the designer's intent.

Future work will include the investigation of methods to design an optimal structure as opposed to just an elemental branch. One possibility is to use network optimization tools to

generate an optimal flow network. Geometric or performance properties of each node would dictate constraints on a specific branch element. Then an optimal element could be found with this genetic algorithm tool, or with some other method.

Future work will also include the modeling of flexible walls, which would more closely match the BHEX concept of a flexible membrane. If the genetic algorithm approach is used, the algorithm could be initialized from optimal rigid-walled solutions.

## REFERENCES

- [1] Pedley, T. J., 1977, "Pulmonary Fluid Dynamics," *Annual Review of Fluid Mechanics*, **9**(1) pp. 229-274.
- [2] Bejan, A., 2000, "Shape and structure, from engineering to nature," Cambridge Univ Pr, .
- [3] Sherman, T., 1981, "On Connecting Large Vessels to Small. the Meaning of Murray's Law," *Journal of General Physiology*, **78**(4) pp. 431-453.
- [4] Gosselin, L., Tye-Gingras, M., and Mathieu-Potvin, F., 2009, "Review of Utilization of Genetic Algorithms in Heat Transfer Problems," *International Journal of Heat and Mass Transfer*, **52**(9-10) pp. 2169-2188.
- [5] Deb, K., Pratap, A., Agarwal, S., 2002, "NSGA-II," *IEEE Transactions on Evolutionary Computation*, **6**(2) .
- [6] Konak, A., Coit, D. W., and Smith, A. E., 2006, "Multi-Objective Optimization using Genetic Algorithms: A Tutorial," *Reliability Engineering & System Safety*, **91**(9) pp. 992-1007.
- [7] Deb, K., and Goyal, M., 1996, "A Combined Genetic Adaptive Search (GeneAS) for Engineering Design," *Computer Science and Informatics*, **26**pp. 30-45.